

CATALOGUE PIÈCES DÉTACHÉES (C A D R E)

TARIF pièces



TX 202-204 Gran Turismo

22061 BARZAGO (Como) Italy

FANTIC FMOTOR

VÉHICULES RÉCRÉATIFS

DIP importateur exclusif

32 BOULEVARD D' AHTÈNES
13001 - MARSEILLE - FRANCE
Téléphone: (91) 620.495

CONCESSIONNAIRE :

1	200.01.5001	1	CADRE	99	367.00	647.80
-	101.02.5200	1	JEU CUVETTES DIRECTION	99	17.65	31.20
2	101.02.5220	1	CONE SUPERIEUR	99	4.50	7.95
3	101.02.5230	1	CALOTTE SUPERIEURE	99	4.00	7.10
3a	101.02.5600	1	" " INFERIEURE	99	3.60	6.40
4	101.02.5280	2	BUTEE A BILLE	99	0.70	1.25
5	101.02.5210	1	CONE INFERIEUR	99	4.50	7.95
6	090.02.5240	1	ECROU DE DIRECTION	99	4.00	7.10
7	090.02.5250	1	RONDELLE	99	0.50	0.90
-	202.02.5000	1	FOURCHE AV. CPLT.	99	249.50	440.40
8	130.02.5271	1	PLAQUE SUPERIEURE	99	60.00	105.90
9	200.02.5290	1	TE DE FOURCHE INF.	99	74.20	131.00
-	200.02.5800	1	JAMBE GAUCHE CPLT.	99	128.00	225.95
-	200.02.5810	1	" DROITE "	99	128.00	225.95
10	200.02.5020	2	PLONGEUR DE FOURCHE	99	55.00	97.10
11	944.01.0825	2	VIS TE 8X25	99	0.30	0.55
12	969.50.0008	2	RONDELLE Ø 8	99	0.10	0.20
13	201.02.5310	1	BAS DE FOURCHE DROIT	99	49.00	86.50
14	201.02.5350	1	" " " " GAUCHE	99	49.00	86.50
15	200.02.5040	2	RESSORT DE FOURCHE	99	11.00	19.45
16	200.02.5370	2	AXE PORTE-RESSORT	99	9.00	15.90
17	200.02.5190	2	RESSORT DE FIN DE COURSE	99	2.30	4.10
18	944.01.0835	1	VIS TE 8X35	99	0.25	0.45
19	200.02.5390	2	FOURREAU CAOUTCHOUC	99	5.00	8.85
20	954.04.0840	4	VIS TCEI 8X40	99	1.40	2.50
21	091.02.5321	2	PORTE-PHARE	99	2.50	4.45
22	091.02.5540	4	COLLIER	99	2.00	3.55
23	944.01.0616	4	VIS TE 6X16	99	0.20	0.40
24	966.48.0006	4	ECROU Ø 6	99	0.30	0.55
25	090.02.5280	2	PONTET FIX. GUIDON	99	3.50	6.20
26	951.01.0655	4	VIS TE 6X55	99	0.50	0.90
27	966.48.0006	4	ECROU Ø 6	99	0.30	0.55

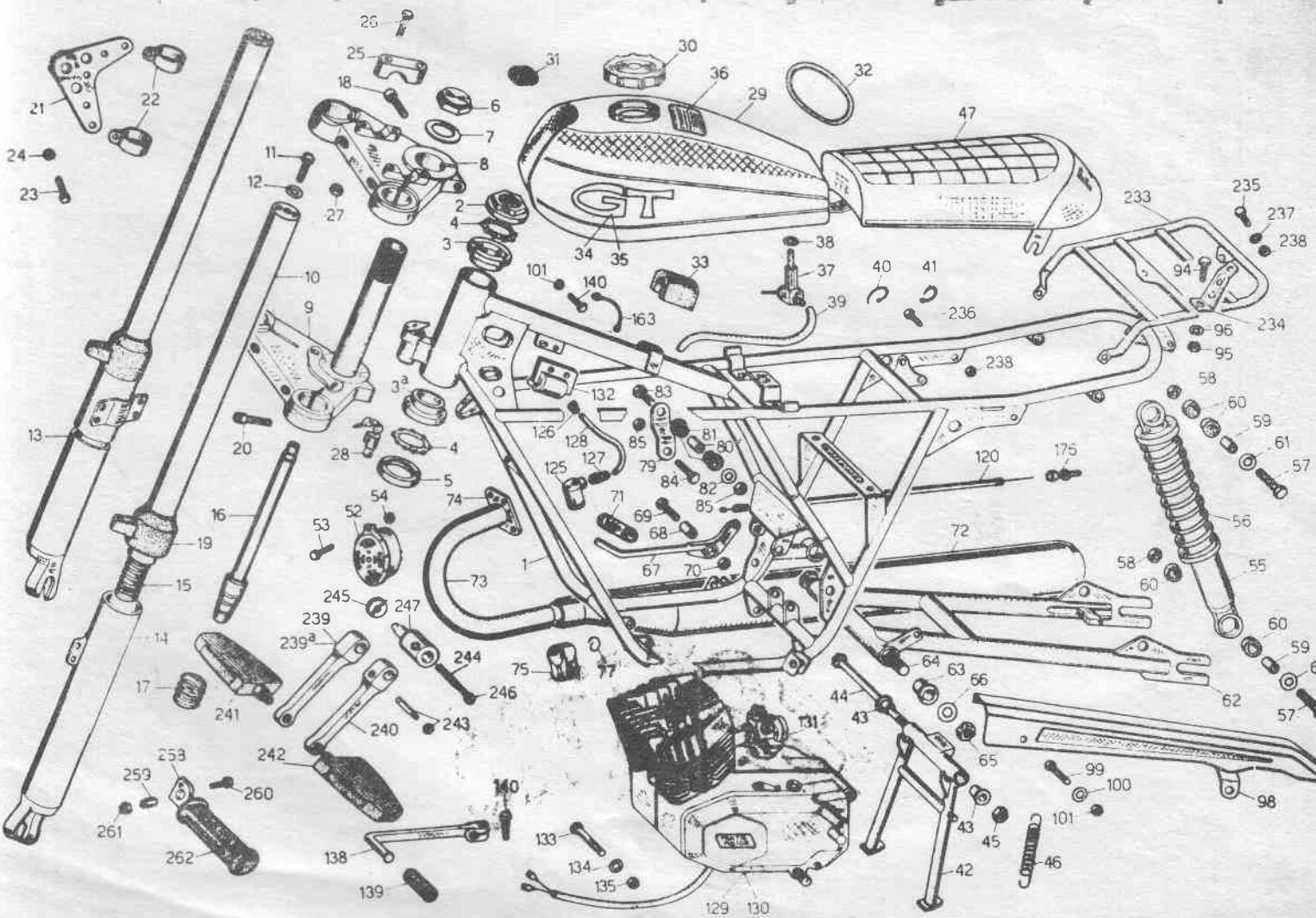

REP.	REFERENCE	DESIGNATION	ED	NET HT	HTC PGG.	CASIER
28	072.02.5151	1 ANTIVOL	99	18.50	32.70	
29	200.05.5000	1 RESERVOIR	99	138.00	243.60	
30	101.05.5010	1 BOUCHON RESERVOIR	99	7.00	12.40	
31	098.05.5020	2 SILENTBLOCK AV. RESERV.	99	1.00	1.80	
32	090.05.5180	1 ELASTIQUE DE RESERVOIR	99	1.50	2.65	
33	090.10.6030	1 TAMPON AR. RESERVOIR	99	2.00	3.55	
34	200.14.6020	1 DECALQUE / RESERV. G.	99	2.50	4.45	
35	200.14.6190	1 " " " " D.	99	2.50	4.45	
36	200.14.6220	1 " " RODAGE	99	0.80	1.45	
37	090.05.5050	1 ROBINET ESSENCE CPLT.	99	11.70	20.70	
38	020.05.5060	1 JOINT ROBINET	99	0.50	0.90	
39	090.05.5100	1 DURITE	99	1.00	1.80	
40	050.10.5011	1 COLLIER SERRE-FIL	99	0.30	0.55	
41	099.10.5010	6 " " " " "	99	0.40	0.75	
42	200.03.5300	1 BEQUILLE	99	26.00	45.90	
43	160.03.5190	2 BAGUE DE BEQUILLE	99	1.00	1.80	
44	200.03.5180	1 AXE DE BEQUILLE	99	2.50	4.45	
45	960.41.0010	1 ECROU Ø 10	99	0.25	0.45	
46	150.03.5100	1 RESSORT DE BEQUILLE	99	1.60	2.85	
47	200.06.5000	1 SELLE MONOPLACE	99	84.50	149.15	
47	201.06.5000	1 SELLEBIPLACE	99	104.00	183.60	
—	201.06.5580	1 TROUSSE OUTIL CPLT.	99	11.00	19.45	
48	090.06.5351	1 " " " " NU	99	3.05	5.40	
49	030.06.5210	1 CLE 19/21	99	2.95	5.25	
50	030.06.5130	1 CLE 10/13	99	2.55	4.55	
51	030.06.5500	1 BROCHE	99	1.00	1.80	
52	070.11.5700	1 KLAXON	99	16.40	28.95	
53	944.01.0614	1 VIS TE 6X14	99	0.20	0.40	

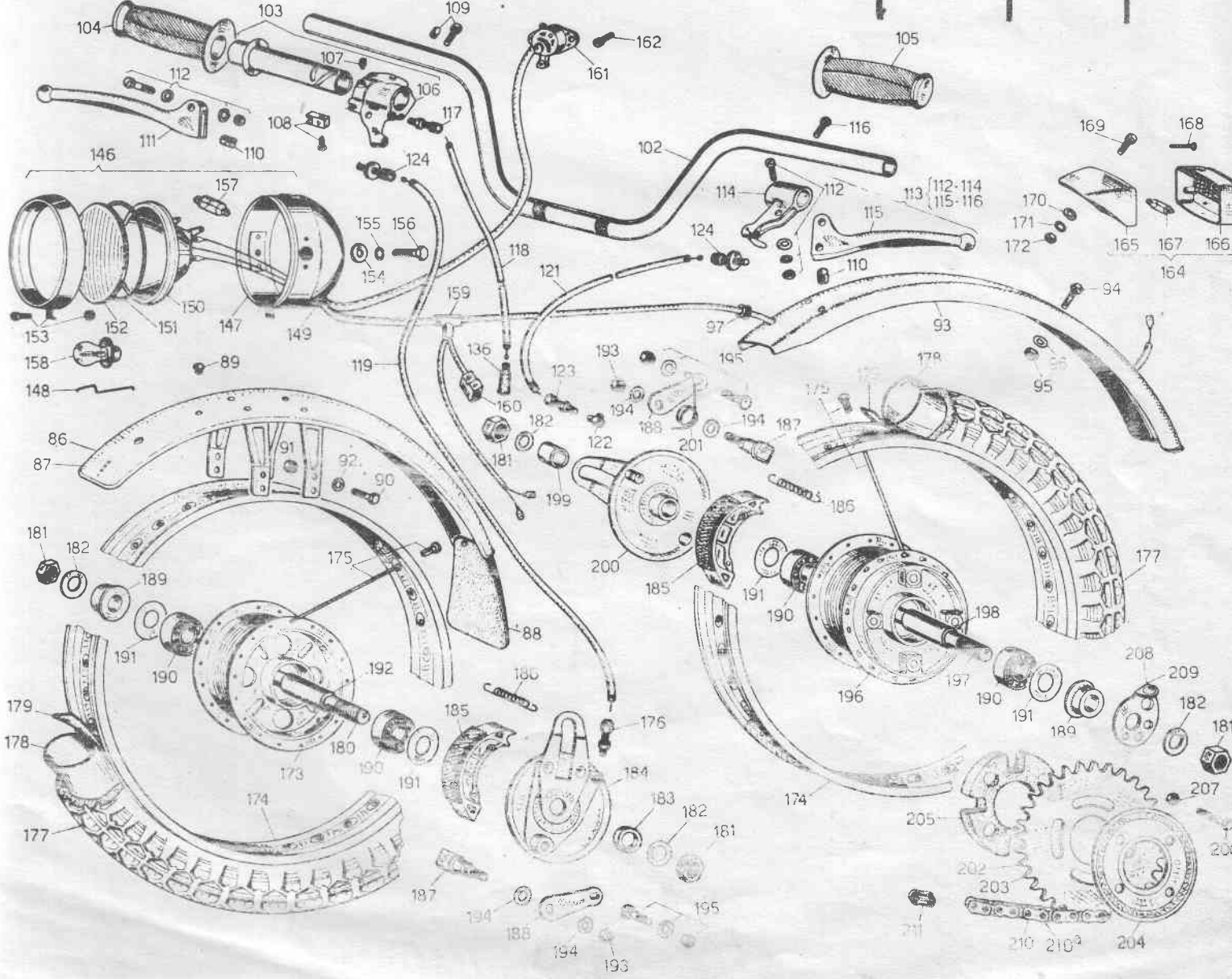

Rep.	REFERENCE	NB	DESIGNATION	CD	CASIER	NET HT	TTC Pub.	CASIER
54	966.48.0006	99	ECROU Ø 6	99		0.30	0.55	
55	201.01.5200	99	AMORTISSEUR	99		45.00	79.45	
56	201.01.5270	99	RESSORT D'AMORTISSEUR	99		26.00	45.90	
57	952.01.1035	99	VIS TE 10X35	99		1.30	2.30	
58	960.49.0010	99	ECROU Ø 10	99		0.35	0.65	
59	010.01.5220	99	ENTRETOISE	99		0.35	0.65	
60	010.01.5210	8	SILENTBLOCK	99		0.35	0.65	
61	969.50.0010	2	RONDELLE Ø 10	99		0.10	0.20	
62	201.01.5100	1	FOURCHE AR.	99		71.00	125.35	
63	200.01.5110	2	BAGUE DE FOURCHE AR.	99		1.00	1.80	
64	010.01.5120	1	AXE DE FOURCHE AR.	99		4.10	7.25	
65	960.19.0012	1	ECROU Ø 12	99		0.30	0.55	
66	969.50.2212	1	RONDELLE Ø 12X22	99		0.10	0.20	
67	200.03.5140	1	PEDALE DE FREIN AR.	99		15.20	26.85	
68	060.07.6310	1	BAGUE DE PEDALE	99		1.00	1.80	
69	952.01.1040	1	VIS TE 10X40	99		1.30	2.30	
70	960.49.0010	1	ECROU Ø10	99		0.35	0.65	
71	091.10.5892	1	CAOUTCHOUC DE PEDALE	99		0.60	1.10	
72	200.13.5050	1	POT D'ECHAPPEMENT	99		66.00	116.50	
73	202.13.5320	1	COUDE ECHAPP. Ø 28	99		39.10	69.05	
74	121.13.5120	1	PLAQUETTE ECHAPP. Ø 28	99		5.00	8.85	
75	096.13.5330	1	COLLIER FIX. POT. Ø 35	99		2.55	4.55	
77	096.13.5250	1	JOINT TORIQUE	99		4.95	8.75	
79	120.13.5130	1	PLAQUE FIX. POT	99		2.50	4.45	
80	120.10.6830	1	BUSELURE	99		0.45	0.80	
81	120.10.6820	2	SILENTBLOCK	99		0.80	1.45	
82	969.54.2408	2	RONDELLE Ø 8X24	99		0.20	0.40	
83	951.01.0835	1	VIS TE 8X35	99		0.70	1.25	
84	944.01.0814	1	VIS TE 8X14	99		0.30	0.55	
85	966.48.0008	2	ECROU Ø 8	99		0.30	0.55	
86	201.09.5500	1	GARDE-BOUE AV. CPLT.	99		38.00	67.10	
88	090.10.5761	1	BAVETTE	99		2.60	4.60	
89	122.09.5280	2	BOUCHON DE G.B.	99		0.20	0.40	
90	944.01.0614	8	VIS TE 6X14	99		0.20	0.40	
91	966.48.0006	8	ECROU Ø 6	99		0.30	0.55	
92	969.50.0006	3	RONDELLE Ø 6	99		1.15	2.05	
93	201.09.5010	1	GARDE-BOUE AR.	99		31.50	55.60	
94	944.01.0614	5	VIS TE 6X14	99		0.20	0.40	
95	966.48.0006	5	ECROU Ø 6	99		0.30	0.55	
96	969.50.0006	5	RONDELLE Ø6	99		1.15	2.05	
97	091.10.5930	1	PASSE-FIL	99		0.30	0.55	
98	200.09.5190	1	CARTER DE CHAINE	99		18.00	31.80	
99	944.01.0612	1	VIS TE 6X12	99		0.20	0.40	
100	969.50.0006	1	RONDELLE Ø 6	99		1.15	2.05	
101	966.48.0006	3	ECROU Ø 6 AB	99		0.30	0.55	
102	200.04.5500	1	GUIDON	99		27.00	47.70	
103	231.04.5000	1	COMMANDE GAZ CPLT.	99		20.30	35.85	
104	090.04.5201	1	POIGNEE CAOUTCHOUC D.	99		2.00	3.55	
105	090.04.5211	1	" " " " C.	99		2.00	3.55	
106	231.04.5010	1	PORTE-LEVIER FREIN AV.	99		9.50	16.80	
107	108.04.5020	1	VIS DE REGLEUR GAZ	99		0.30	0.55	
108	121.04.5040	1	GLISSANT DE CDE. GAZ	99		1.00	1.80	
109	060.04.5120	1	VIS ET BAGUE	99		0.80	1.45	
110	099.04.5150	2	NIPPLE	99		0.60	1.10	
111	124.04.5130	1	LEVIER FREIN AV.	99		11.90	21.05	
112	944.06.0525	2	VIS TC 6C25	99		0.30	0.55	
113	231.04.5100	1	COMMANDE EMBRAYAGE	99		17.50	30.90	
114	201.04.5260	1	PORTE-LEVIER EMBRAYAGE	99		9.50	16.80	
115	124.04.5230	1	LEVIER EMBRAYAGE	99		11.90	21.05	
117	124.04.5850	1	REGLEUR GAZ	99		2.00	3.55	
116	954.04.0616	1	VIS TCEI 6X16	99		0.40	0.75	

Rep.	REFERENCE	NB	DESIGNATION	CD	NET HT	TTC Pub.	CASIER
118	201.04.5300	1	TRANSMISSION GAZ	99	2.25	4.00	
119	091.04.5432	1	" " FREIN AV.	99	4.20	7.45	
120	201.04.5360	1	" " " " AR.	99	2.25	4.00	
121	201.04.5430	1	" " EMBRAYAGE	99	3.85	6.80	
122	060.04.5440	1	SERRE-CABLE EMBR.	99	0.50	0.90	
123	020.07.6120	1	REGLEUR EMBRAYAGE	99	1.00	1.80	
124	124.04.5890	2	REGLEUR FREIN EMBR.	99	2.00	3.55	
125	124.11.6750	1	ANTIPARASITE	99	11.20	19.80	
126	124.11.6760	1	PROTECTION FIL HT	99	1.20	2.15	
127	124.11.6770	1	" " BOUGIE	99	5.00	8.85	
128	090.11.5570	1	FIL HT POUR BOUGIE	99	2.30	4.10	
129	202.13.5650	1	MOTEUR SP4 CPLT.	99	1187.80	1955.60	
130	096.13.5671	1	" " SP6 CPLT.	99	1411.20	2323.40	
131	001.50.1590	1	CARBURATEUR SHA 14/12	99	66.60	117.55	
132	000.72.0290	1	BOBINE HT EXT. DUCATI	99	58.60	103.45	
132	180.11.6210	1	" " " " C.E.V.	99	71.55	126.30	
133	951.01.0865	3	VIS TE 8X65	99	1.00	1.80	
134	969.50.0008	3	RONDELLE	99	0.10	0.20	
135	963.48.0008	3	ECROU Ø 8	99	0.30	0.55	
136	070.10.5790	1	PROTECTION TR. GAZ	99	0.35	0.65	
137	090.10.6570	1	COLLIER FIX. SOUFFLET	99	3.00	5.30	
138	150.13.5081	1	PEDALE SELECTEUR	99	17.65	31.20	
139	091.10.5892	1	CAOUTCHOUC PEDALE	99	0.60	1.10	
140	944.01.0620	3	VIS FIX. PEDALE	99	0.20	0.40	
146	202.11.6001	1	PHARE AV. CPLT.	99	65.00	114.75	
147	200.11.5100	1	CORPS DE PHARE	99	43.50	76.80	
148	060.11.5060	3	RESSORT DE VERRE	99	1.00	1.80	
149	103.11.5160	1	PASSE-FIL	99	1.00	1.80	
150	100.11.5030	1	PARABOLE	99	29.65	52.35	
151	100.11.5260	1	JOINT DE VERRE	99	2.50	4.45	
152	100.11.5020	1	VERRE DE PHARE	99	7.00	12.40	
153	103.11.5050	1	CERCLE DE PHARE	99	19.80	34.95	
154	102.01.5011	2	BAGUE	99	0.45	0.80	
155	969.60.0008	2	RONDELLE Ø 8	99	0.10	0.20	
156	944.01.0816	2	VIS TE 8X16	99	0.40	0.75	
157	098.11.5080	1	AMPOULE 6V 15W	99	5.90	10.45	
158	098.11.5070	1	" " " 6W	99	6.00	10.60	
159	202.11.5601	1	CABLAGE ELECTRIQUE	99	37.00	65.35	
160	121.11.5620	1	BROCHE DE CONNECTION F.	99	0.45	0.80	
161	202.11.5500	1	COMMUTATEUR	99	35.00	61.80	
162	944.02.0410	2	VIS TC 4X10	99	0.20	0.40	
163	091.11.5220	1	FIL DE MASSE	99	1.00	1.80	
164	170.11.6310	1	FEU ROUGE AR. CPLT.	99	13.30	23.50	
165	170.11.6700	1	CORPS DE FEU AR.	99	7.60	13.45	
166	120.11.6330	1	VERRE DE FEU ROUGE	99	9.45	16.70	
167	098.11.6980	1	AMPOULE 3W AR	99	3.95	7.00	
168	061.11.6720	2	VIS DE VERRE	99	1.00	1.80	
169	944.02.0515	2	VIS TC 5X15	99	0.20	0.40	
170	969.50.0005	2	RONDELLE Ø 5	99	0.10	0.20	
171.	969.60.0005	2	" " Ø 5	99	0.20	0.40	
172	960.48.0005	2	ECROU Ø 5	99	0.25	0.45	
—	202.07.5000	1	ROUE AV. CPLT.	99	189.00	333.60	
—	123.07.5060	1	MOYEU AV. CPLT.	99	84.00	148.30	
173	123.07.5040	1	" " " NU	99	35.00	61.80	
174	200.07.5070	1	JANTE AV. AR.	99	55.45	97.90	
175	200.07.5160	36	RAYON+ NIPPLE	99	1.05	1.90	
176	020.07.6120	2	REGLEUR FREIN	99	1.00	1.80	
177	200.12.3600	2	PNEU AV. AR. 275X18	99	96.00	146.80	
178	200.12.3610	2	CHAMBRE A AIR	99	22.35	39.45	
179	120.10.6021	2	PROTEGE CHAMBRE	99	1.00	1.80	
180	121.07.5020	1	AXE DE ROUE AV.	99	5.00	8.85	

Rep.	REFERENCE	QUANT	DESIGNATION	CD	co	co	co	co	co
181	030.07.5210	4	ECROU D'AXE DE ROUES	99					1.00 1.80
182	030.07.5220	4	RONDELLE	99					0.40 0.75
183	130.07.5050	1	ENTRETOISE GAUCHE	99					1.80 3.20
—	123.07.5900	1 DIS	DISQUE P.M. AV. CPLT.	99					35.50 62.70
184	123.07.5910	1	" " " " NU1	99					16.20 28.60
185	090.07.5920	4	MACHOIRE DE FREIN	99					9.45 16.70
186	090.07.5930	4	RESSORT DE MACHOIRE	99					0.60 1.10
187	090.07.5940	2	CAMME	99					2.90 5.15
188	090.07.5950	2	LEVIER FREIN S/ MOYEU	99					1.50 2.65
189	123.07.5030	2	ENTRETOISE	99					2.50 4.45
190	030.07.5230	4	ROULEMENT	99					14.50 25.60
191	030.07.5240	4	RONDELLE	99					0.70 1.25
192	121.07.5250	1	ENTRETOISE INTERNE	99					3.00 5.30
193	960.48.0006	2	ECROU Ø 6	99					0.25 0.45
194	969.50.0006	2	RONDELLE Ø 6	99					1.15 2.05
195	020.07.6100	2	SERRE-CABLE	99					0.80 1.45
—	202.07.5290	1	ROUE AR.CPLT. 4M	99					239.40 422.55
—	204.07.5291	1	" " " " 6M	99					241.30 425.90
—	204.07.5301	1	MOYEU AR. CPLT 6M	99					139.25 245.80
196	123.07.5310	1	" " " " NU	99					43.00 75.90
197	121.07.5120	1	AXE DE ROUE AR.	99					6.80 12.05
198	123.07.5260	1	ENTRETOISE INTERNE	99					3.00 5.30
199	108.07.5140	1	" " " DROITE	99					1.40 2.50
—	123.07.5800	1	DISQUE P.M. AR. CPLT.	99					37.00 65.35
200	123.07.5810	1	" " " " " NU	99					16.20 28.60
201	123.07.5970	1	RESSORT DE LEVIER	99					1.50 2.65
202	204.08.5310	1	COURONNE Z=39	99					42.85 75.65
203	204.08.5370	1	" " " Z=48	99					40.95 72.30
204	102.08.5210	1	RONDELLE FIX. COURONNE	99					3.65 6.45
205	063.07.5330	1	FLECTOR	99					6.00 10.60
206	951.01.0635	4	VIS TE 6X35	99					0.40 0.75
207	960.48.0006	4	ECROU Ø6	99					0.25 0.45
208	030.08.5100	1	TENDEUR CHAINE DROIT	99					1.10 1.95
209	030.08.5110	1	" " " " GAUCHE	99					1.10 1.95
210	091.08.6720	1	CHAINE 112M 4M	99					27.20 48.05
210a	204.08.6720	1	" " 118M 6M	99					28.50 50.35
211	070.08.6360	1	ATTACHE-RAPIDE	99					2.40 4.25
—	090.10.6801	1	GROUPE ASPIRATION CPLT.	99					88.50 156.25

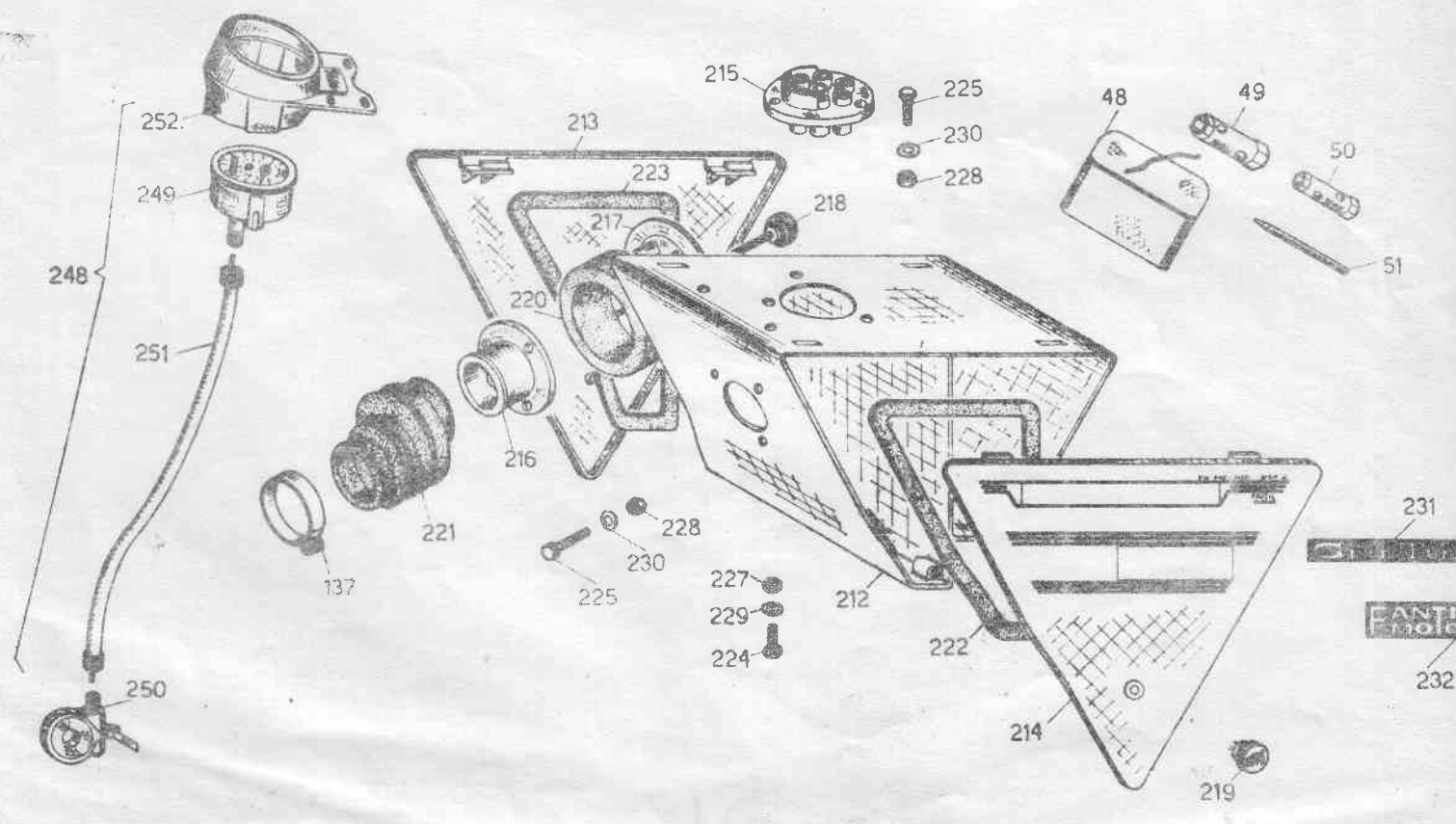

			DESIGNATION	CD	coûtsier	NET	P.T.C. PUB
212	090.10.6441	1	CORPS ASPIRATION	99		27.00	47.70
213	090.10.6482	1	COUVERCLE DROIT	99		8.00	14.15
214	090.10.6491	1	" " " GAUCHE	99		8.00	14.15
215	090.10.6450	1	CARTER ARRIVEE AIR	99		3.20	5.65
216	200.10.6460	1	" " SORTIE AIR	99		3.30	5.85
217	160.10.6470	1	DISQUE PORTE-FILTRE	99		6.50	11.50
218	944.01.0560	4	VIS TE 5X60	99		0.30	0.55
218	960.48.0005	4	ECROU Ø 5	99		0.25	0.45
218	969.50.0005	4	RONDELLE Ø 5	99		0.10	0.20
219	090.10.5561	1	ECROU MOLLETE	99		1.40	2.50
220	090.10.5900	1	ELEMENT FILTRE A AIR	99		7.00	12.40
221	202.10.6530	1	DURITE AIR RIGIDE	99		10.50	18.55
222	090.10.6551	1	JOINT DE COUVERCLE G..	99		1.50	2.65
223	090.10.6561	1	" " " " " D.	99		1.50	2.65
224	944.01.614	4	VIS TE 6X14	99		0.20	0.40
225	944.02.0515	6	VIS TC 5X15	99		0.20	0.40
227	966.48.0006	4	ECROU Ø 6	99		0.30	0.55
228	966.48.0005	6	ECROU Ø 5	99		0.30	0.55
229	969.50.0006	4	RONDELLE Ø 6	99		1.15	2.05
230	969.50.0005	6	RONDELLE Ø 5	99		0.10	0.20
231	200.14.6030	2	DECALQUE "Gran Turismo"	99		1.00	1.80
232	200.14.6180	2	" " " " " F.M."	99		1.00	1.80
233	200.10.5550	1	PORTE-BAGAGES	99		30.80	54.40
234	200.10.5570	1	PLAQUETTE P.G.	99		2.20	3.90
235	944.01.0612	1	VIS TE 6X12	99		0.20	0.40
236	951.01.0635	2	VIS TE 6X35	99		0.40	0.75
237	969.50.0006	6	RONDELLE Ø 6	99		1.15	2.05
238	966.48.0006	3	ECROU Ø 6	99		0.30	0.55
239	201.10.5680	1	MANIVELLE DROITE 4M	99		17.50	30.90
239a	123.10.5680	1	" " " " 6M	99		17.50	30.90
240	123.10.5690	1	" " REVERSIBLE	99		49.60	87.55
241	172.10.5710	1	PEDALE DROITE	99		6.30	11.15
242	172.10.5720	1	" " GAUCHE	99		6.30	11.15
243	072.10.5730	2	CLAVETTE CPLT.	99		1.00	1.80
244	123.10.6250	1	RESSORT	99		0.50	0.90
245	123.10.6260	1	ECROU	99		2.10	3.75
246	944.02.0635	1	VIS TC 6X35	99		0.50	0.90
247	123.10.6230	1	BAGUE	99		21.00	37.10
248	124.10.6600	1	COMPTEUR CPLT.	99		87.60	154.65
249	061.10.5600	1	" " NU	99		78.75	139.00
250	123.10.5610	1	ENTRAINEUR COMPTEUR	99		16.50	29.15
251	090.10.5621	1	TRANSMISSION COMPTEUR	99		14.00	24.75
252	090.10.5980	1	SUPPORT COMPTEUR	99		16.00	28.25
258	200.03.6030	2	FERRE REPOSE-PIED	99		4.05	7.15
259	090.03.6010	2	ENTRETOISE R.P.	99		0.20	0.40
260	944.01.0825	2	VIS TE 8X25	99		0.30	0.55
261	966.48.0008	2	ECROU Ø 8	99		0.30	0.55
262	120.03.6020	2	CAOUTCHOUC R.P.	99		2.50	4.45