

L

CABALLERO 75cc REG. COMPETIZIONE
 CABALLERO 75cc REG. STANDARD

9 - 1980

GRUPPO ASPIRAZIONE-CAMERA D'ESPANSIONE-SILENZIATORE
 GROUPE ASPIRATION-POT D'ECHAPPEMENT-SILENCIEUX
 GROUPE INTAKE-SILENCER-TERMINAL SILENCER
 ANSAUGBAUGRUPPE-AUSPUFF-AUSPUFFSCHALLDAMPFER

**FANTIC
 MOTOR**

L1 CABALLERO 75cc REG. COMPETIZIONE

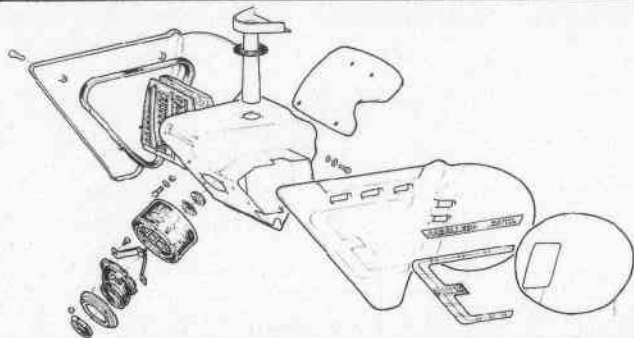

L2 CABALLERO 75cc REG. COMPETIZIONE

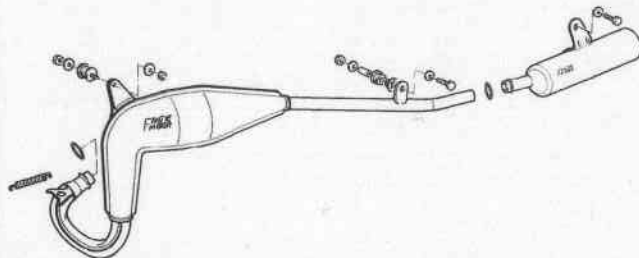

L3

L4 CABALLERO 75cc REG. STANDARD

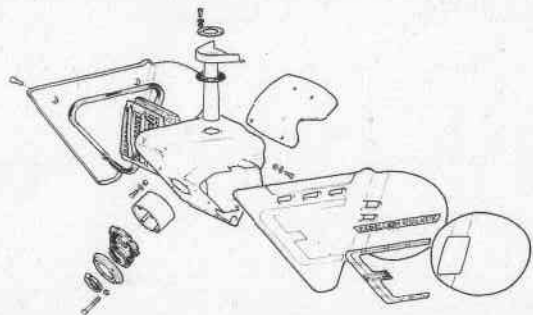

L5 CABALLERO 75cc REG. STANDARD

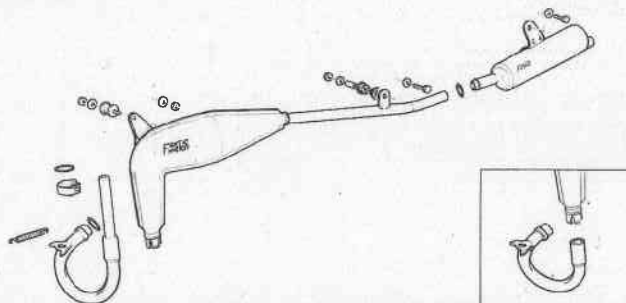

L6

L7 CABALLERO 75cc REG. STANDARD SPAGNA

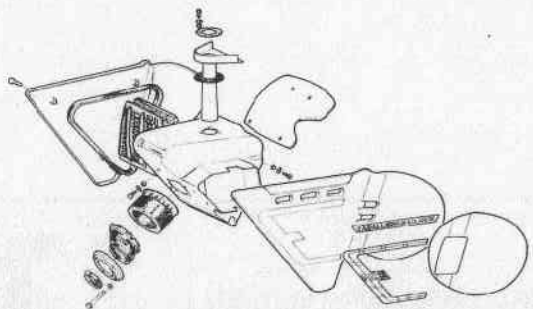

L8

L9

L1

CABALLERO 75cc REG. COMPETIZIONE

9 - 1980

L

1/1

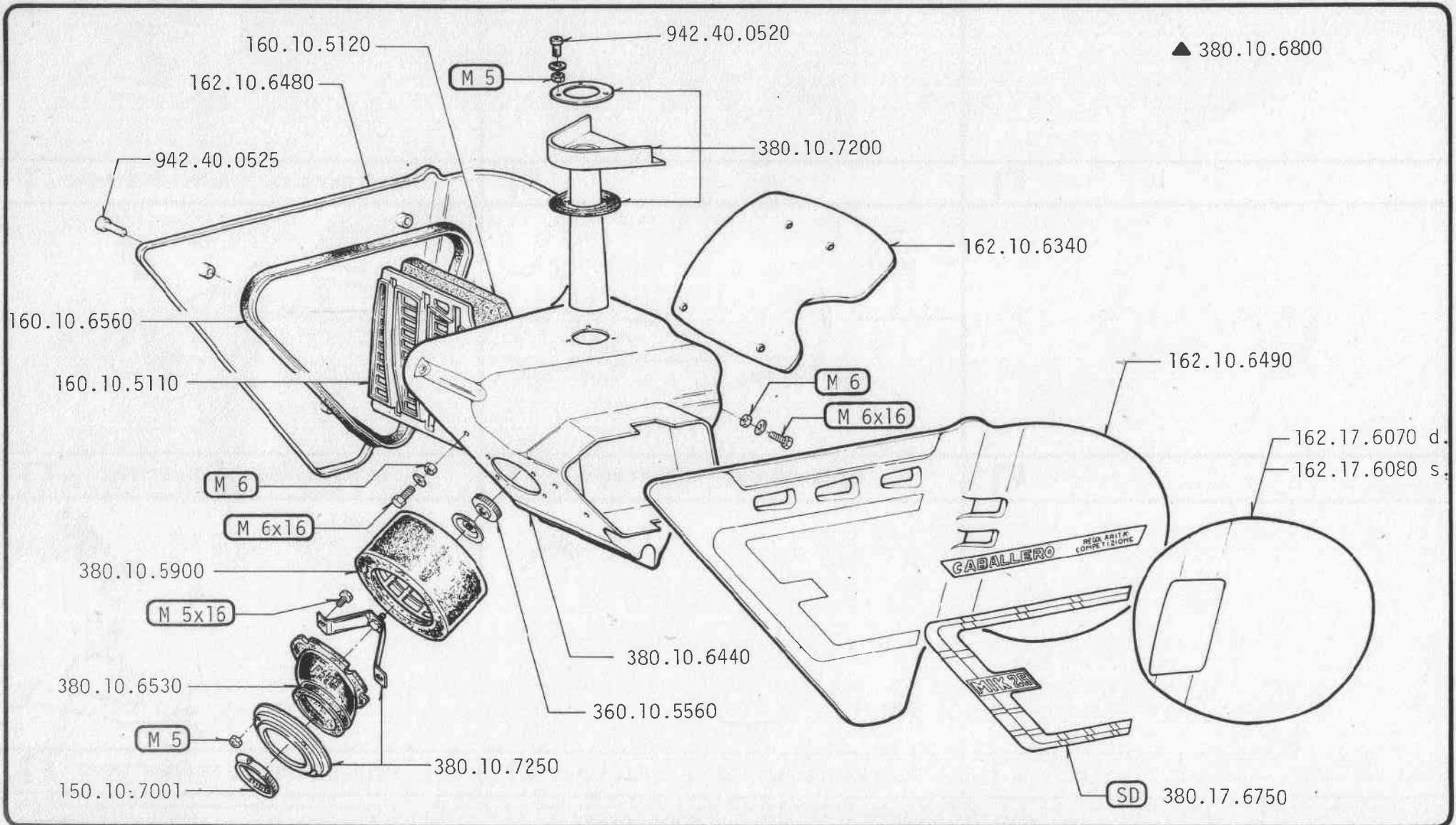
**FANTIC
MOTOR**

▲ Gruppo di aspirazione completo ▲ Groupe aspiration complet ▲ Group intake assembly ▲ Ansaugbaugruppe Komplett

L2

CABALLERO 75cc REG. COMPETIZIONE

9 - 1980

L

2/1

**FANTIC
MOTOR**

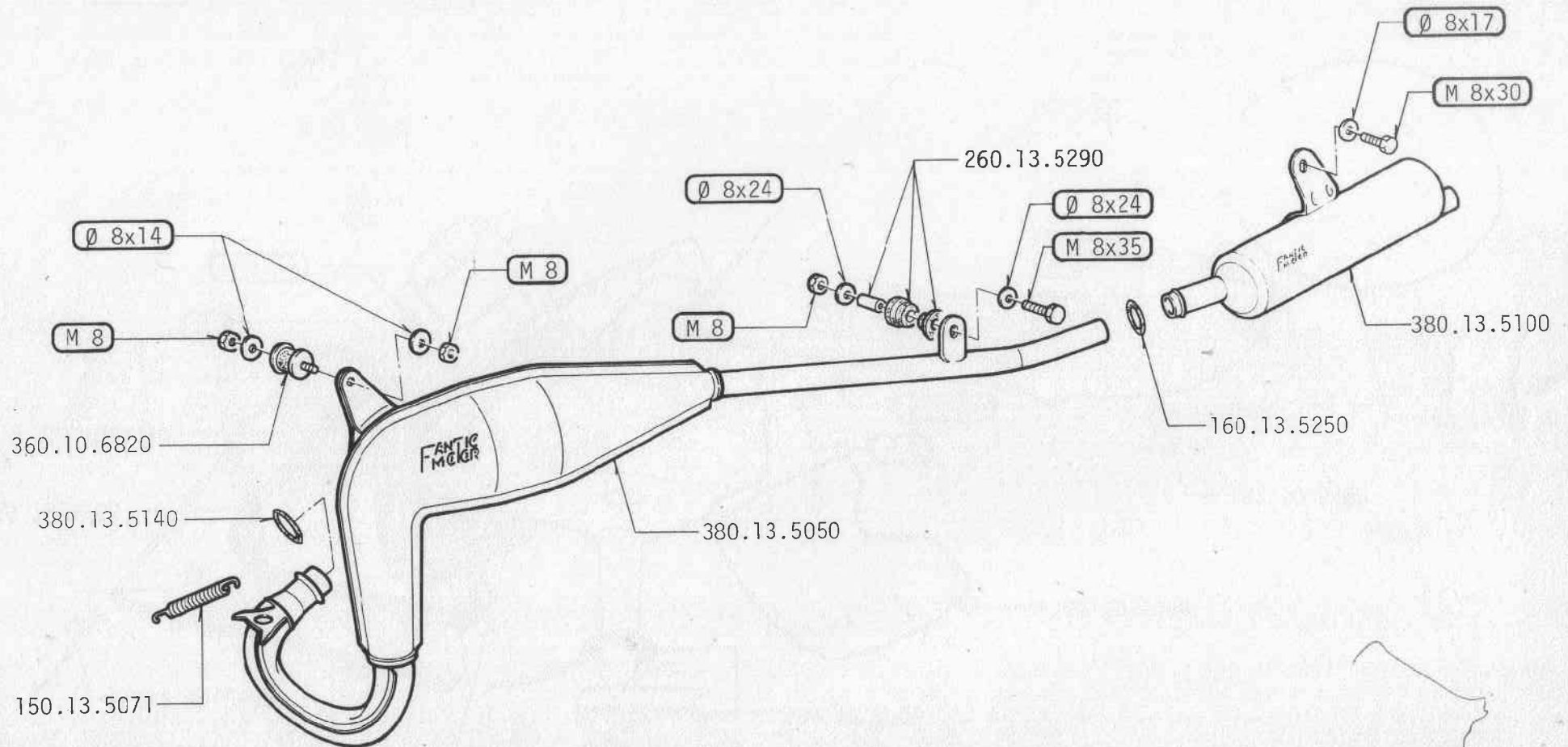

L4

CABALLERO 75cc REG. STANDARD

9 - 1980

L

4/1

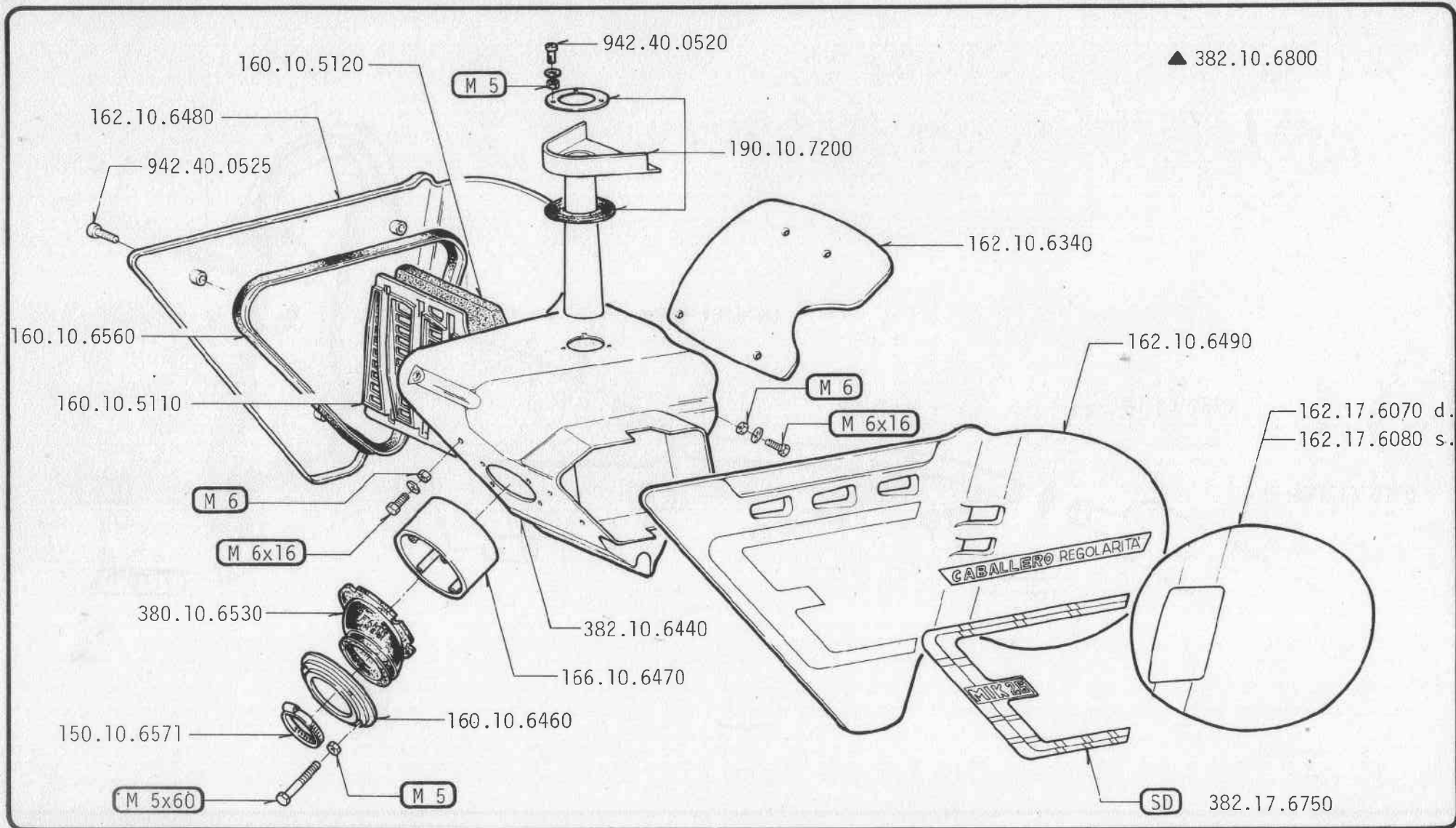
**FANTIC
MOTOR**

▲ Gruppo di aspirazione completo ▲ Groupe aspiration complet ▲ Group intake assembly ▲ Ansaugbaugruppe Komplett

L5

CABALLERO 75cc REG. STANDARD

9 - 1980

L

5/1

FANTIC MOTOR

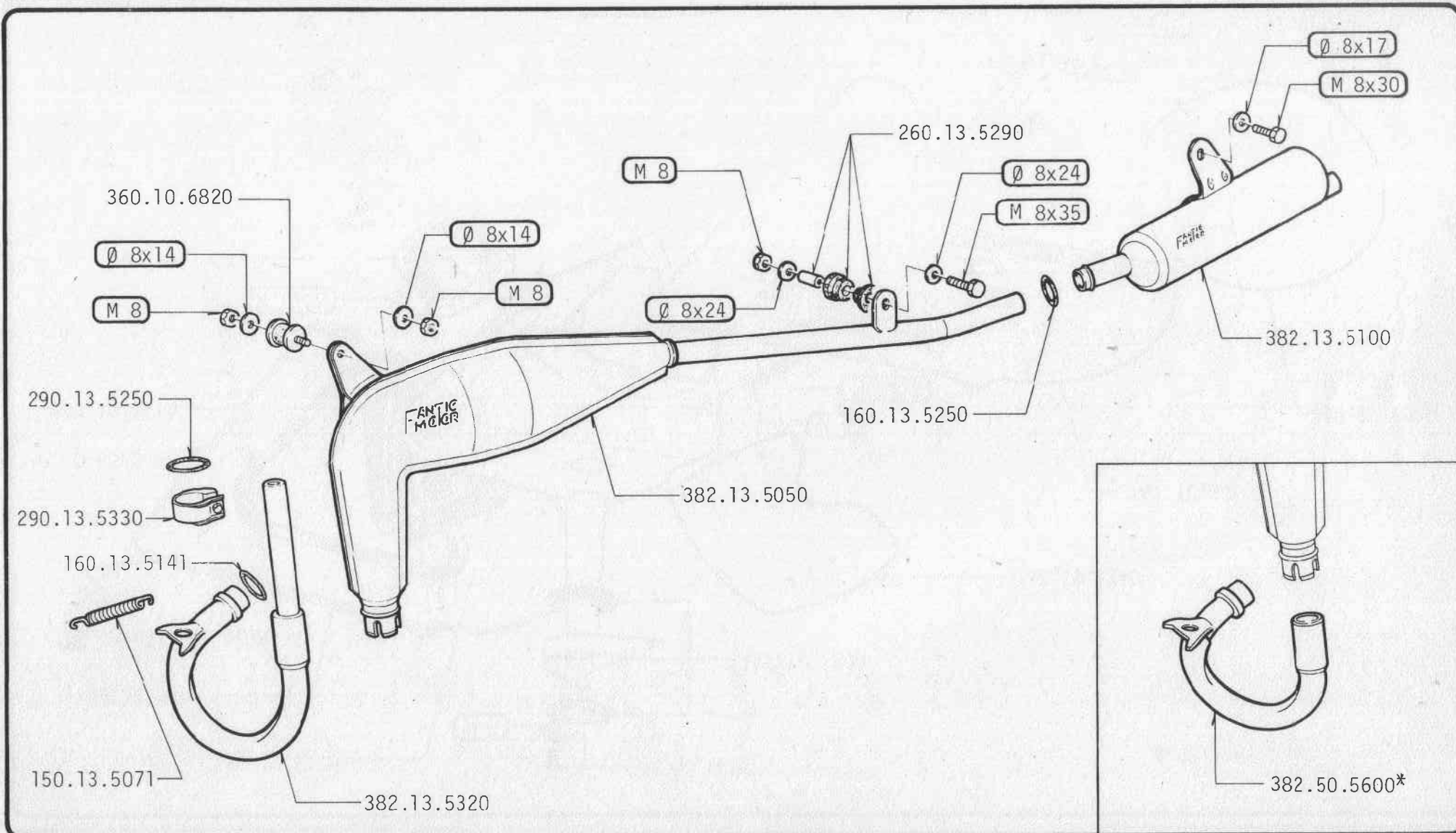

L7

CABALLERO 75cc REG. STANDARD

9 - 1980

Mod. SPAGNA

L

7/1

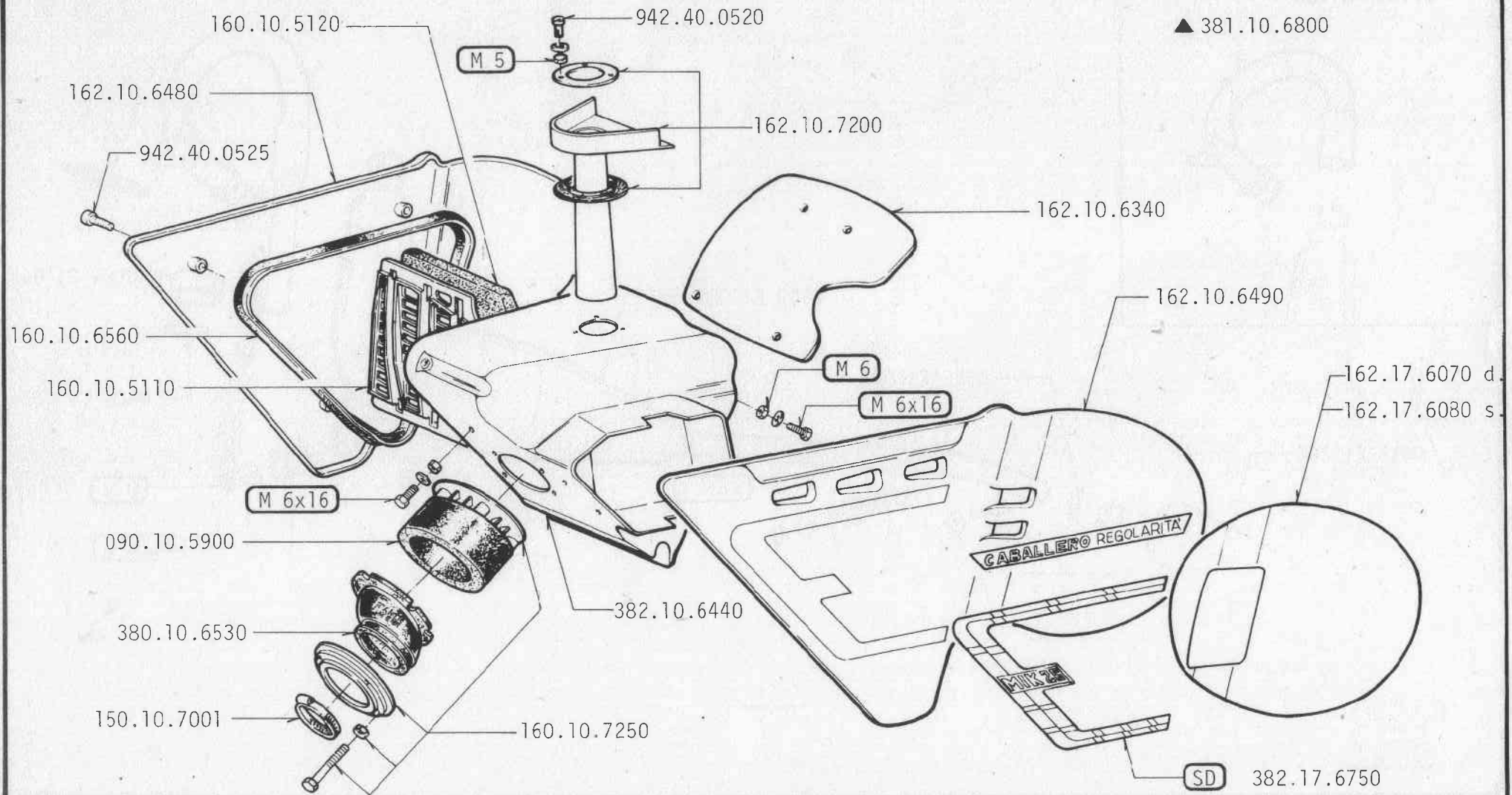
**FANTIC
MOTOR**

▲ Gruppo di aspirazione completo ▲ Groupe aspiration complet ▲ Group intake assembly ▲ Ansaugbaugruppe Komplet

MCABALLERO 75cc REG. COMPETIZIONE
CABALLERO 75cc REG. STANDARD

9 - 1980

CONTACHILOMETRI - SPECCHIETTO RETROVISORE - ACCESSORI
COMPTEUR - RETROVISEUR - ACCESSOIRES
SPEEDOMETER - REAR VIEW MIRROR - ACCESSORIES
TACHOMETER - RUCKSPIEGEL - ZUBEHÖRE**FANTIC
MOTOR**

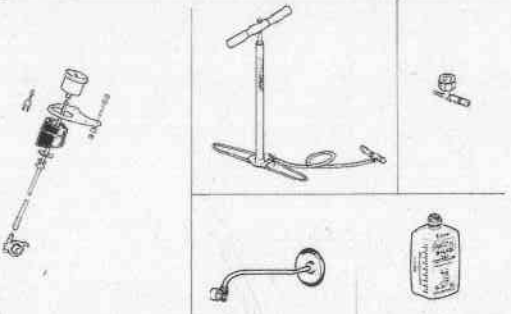
M1 CABALLERO 75cc REG. COMPETIZIONE CABALLERO 75cc REG. STANDARD	M2	M3
		
M4	M5	M6
M7	M8	M9

M1

CABALLERO 75cc REG. COMPETIZIONE
CABALLERO 75cc REG. STANDARD

9 - 1980

M

1/1

FANTIC MOTOR

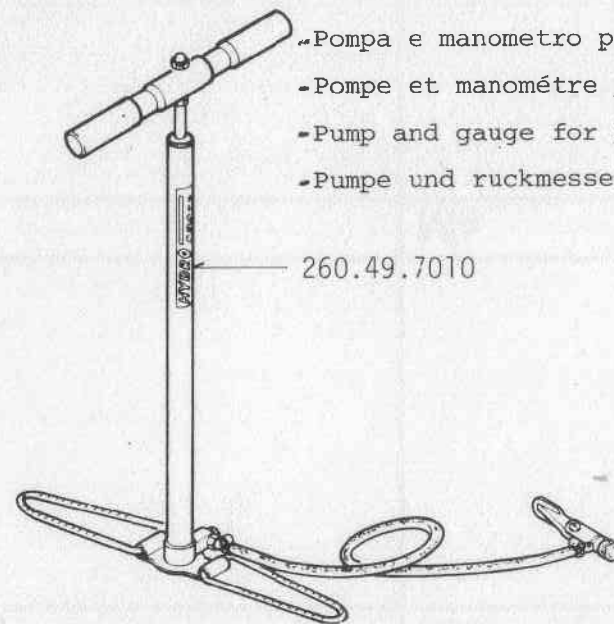
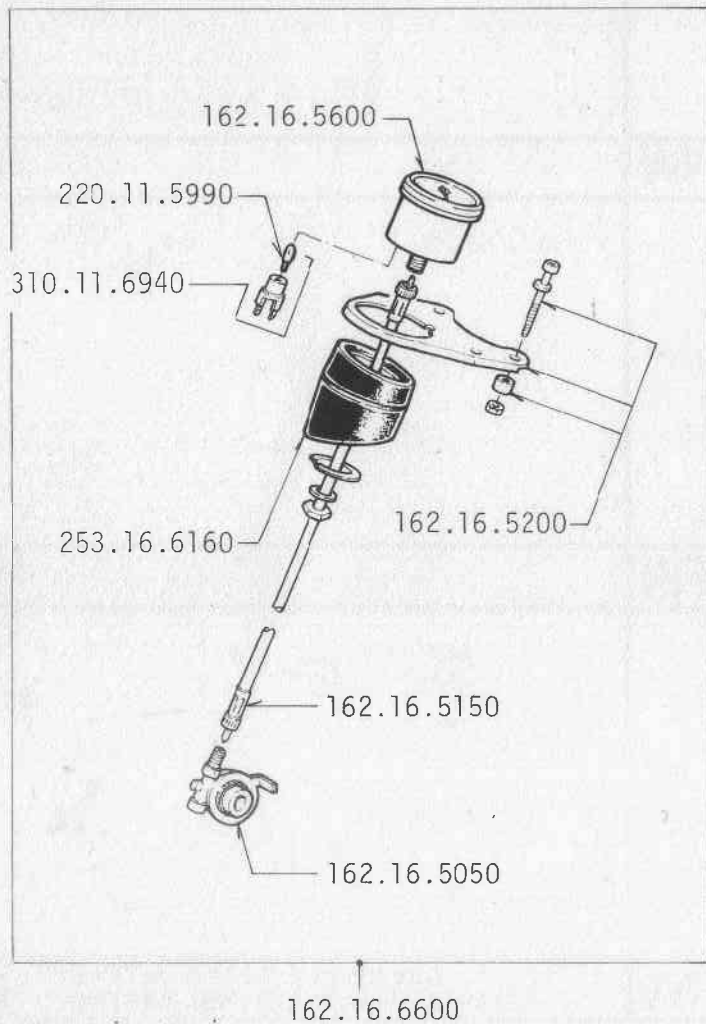

- Pompa e manometro per ammortizzatori hydrocross
- Pompe et manomètre pour amortisseurs hydrocross
- Pump and gauge for hydrocross shock absorbers
- Pumpe und ruckmesser für Hydrocross-stossdämpfer

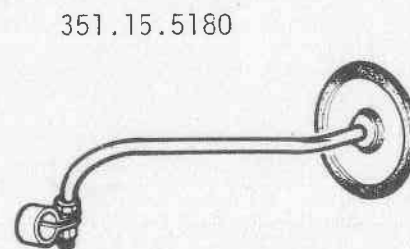
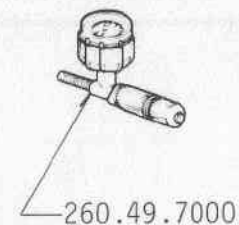

260.55.6030

NCABALLERO 75cc REG. COMPETIZIONE
CABALLERO 75cc REG. STANDARD

9 - 1980

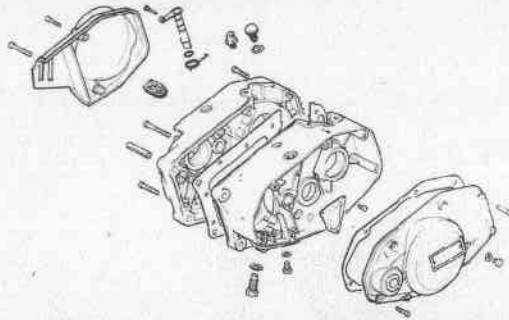
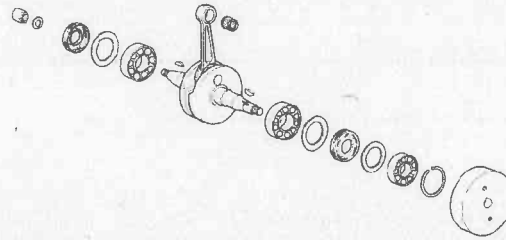
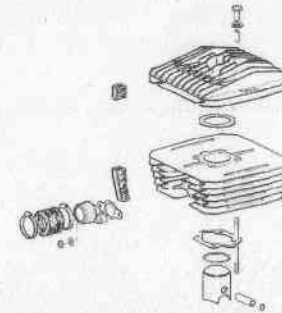
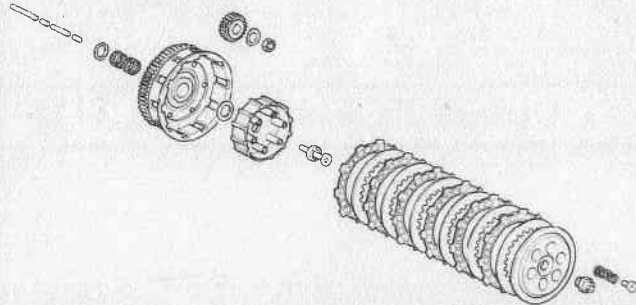
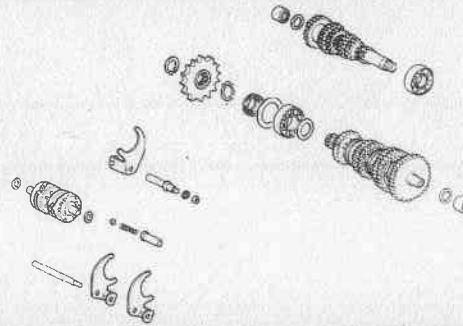
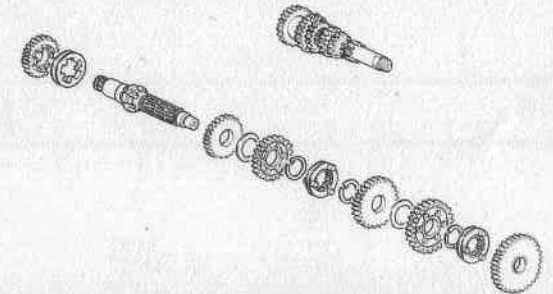
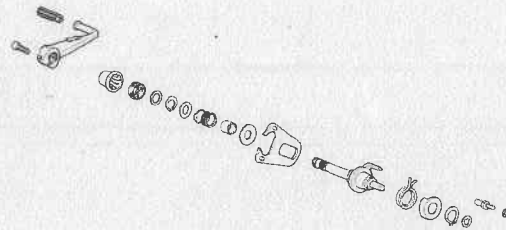
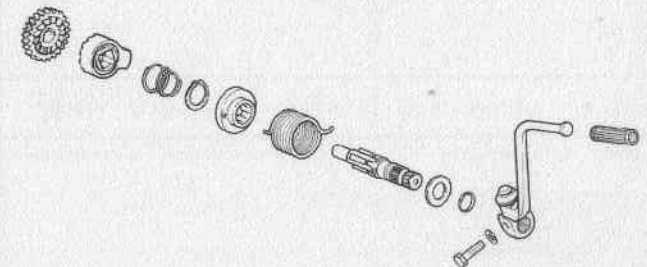
MOTORE
MOTEUR
ENGINE
MOTOR**FANTIC
MOTOR****N1** CABALLERO 75cc REG. COMPETIZIONE
CABALLERO 75cc REG. STANDARD**N2** CABALLERO 75cc REG. COMPETIZIONE
CABALLERO 75cc REG. STANDARD**N3** CABALLERO 75cc REG. COMPETIZIONE**N4** CABALLERO 75cc REG. COMPETIZIONE**N5** CABALLERO 75cc REG. COMPETIZIONE
CABALLERO 75cc REG. STANDARD**N6** CABALLERO 75cc REG. COMPETIZIONE
CABALLERO 75cc REG. STANDARD**N7****N8** CABALLERO 75cc REG. COMPETIZIONE
CABALLERO 75cc REG. STANDARD**N9** CABALLERO 75cc REG. COMPETIZIONE
CABALLERO 75cc REG. STANDARD

NCABALLERO 75cc REG. COMPETIZIONE
CABALLERO 75cc REG. STANDARD

9 - 1980

MOTORE
MOTEUR
ENGINE
MOTOR**FANTIC
MOTOR**

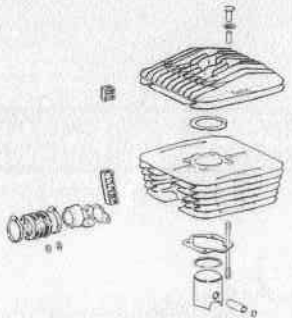
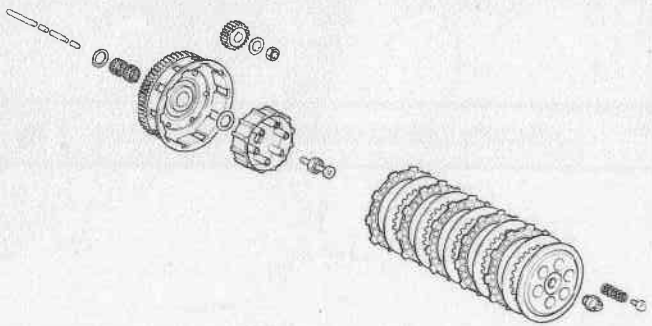
N10	N11	N12 CABALLERO 75cc REG. STANDARD
		
N13 CABALLERO 75cc REG. STANDARD	N14	N15
		
N16	N17	N18

N1

CABALLERO 75cc REG. COMPETIZIONE
CABALLERO 75cc REG. STANDARD

9 - 1980

N

1/1

FANTIC MOTOR

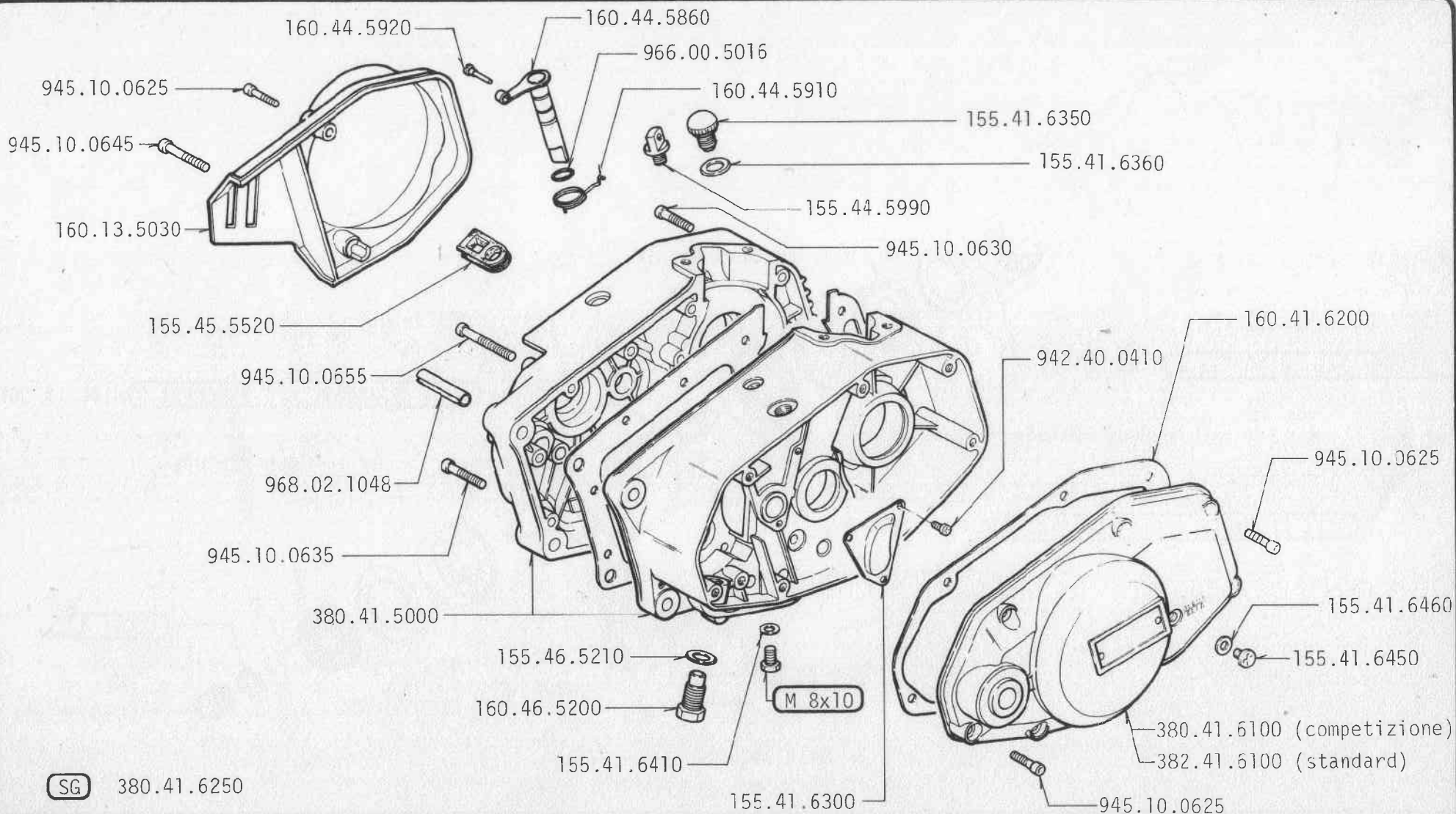

N₂

CABALLERO 75cc REG. COMPETIZIONE
CABALLERO 75cc REG. STANDARD

9 - 1980

N

2/1

FANTIC MOTOR

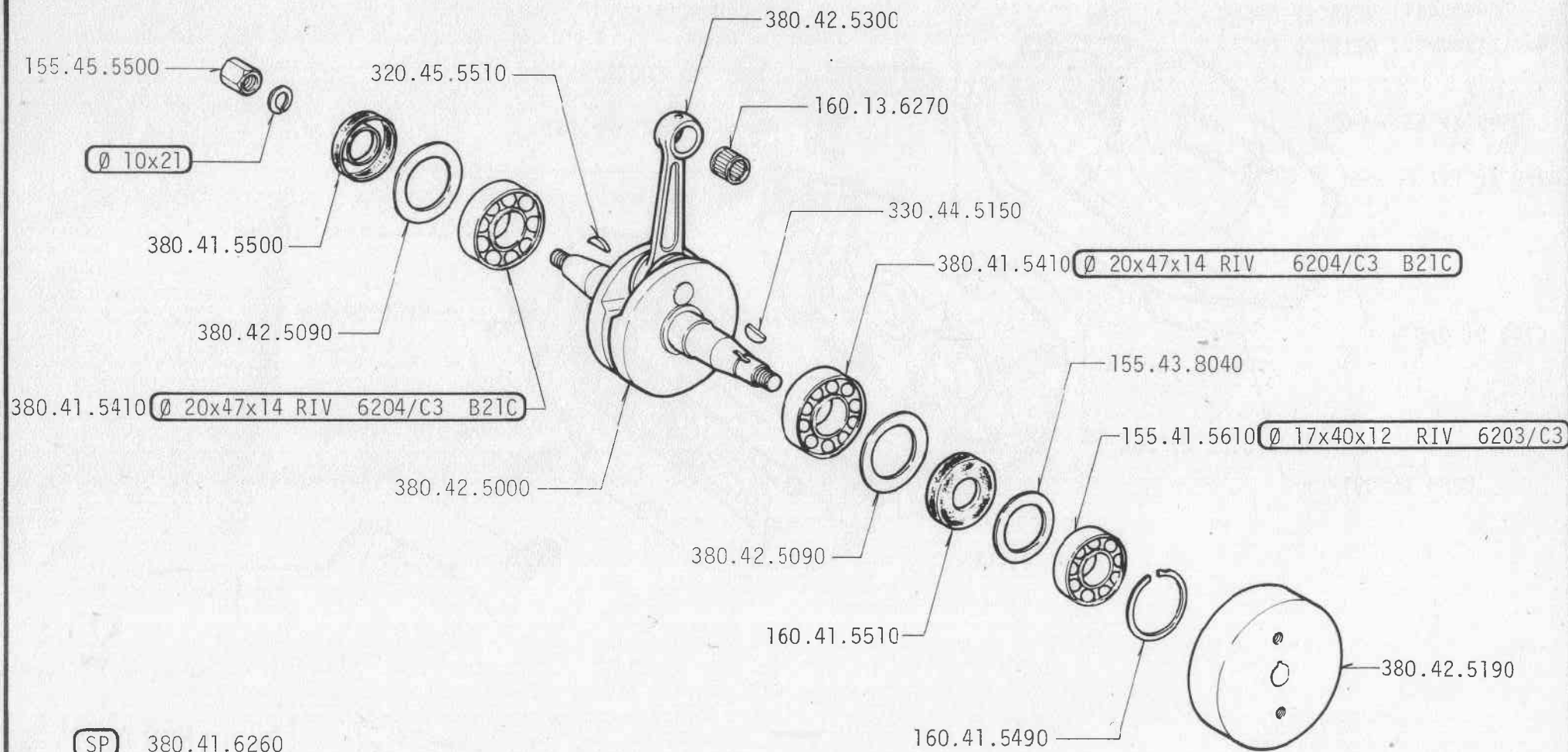

N3

CABALLERO 75cc REG. COMPETIZIONE

9 - 1980

N

3/1

FANTIC MOTOR

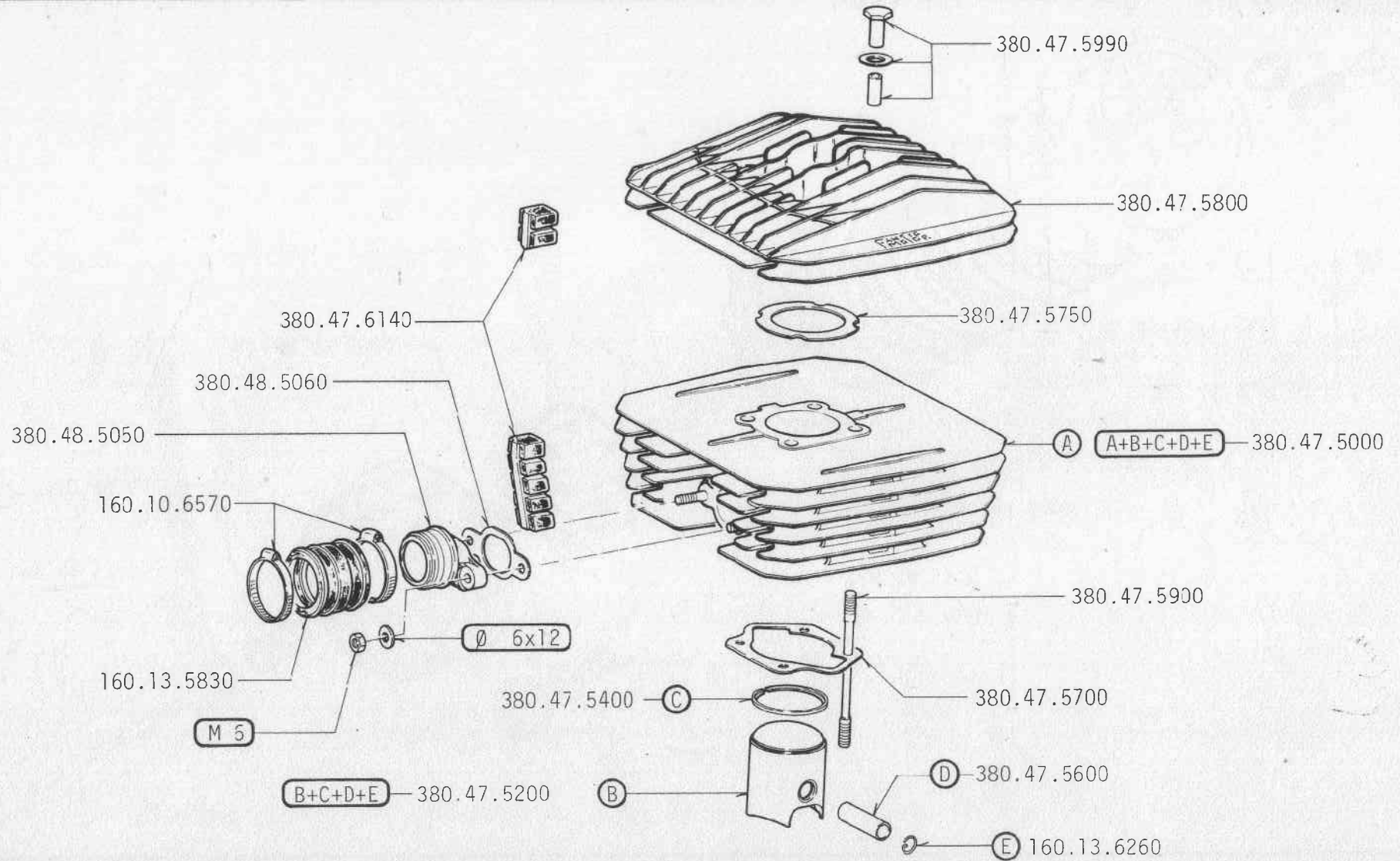

N4

CABALLERO 75cc REG. COMPETIZIONE

9 - 1980

N

4/1

FANTIC MOTOR

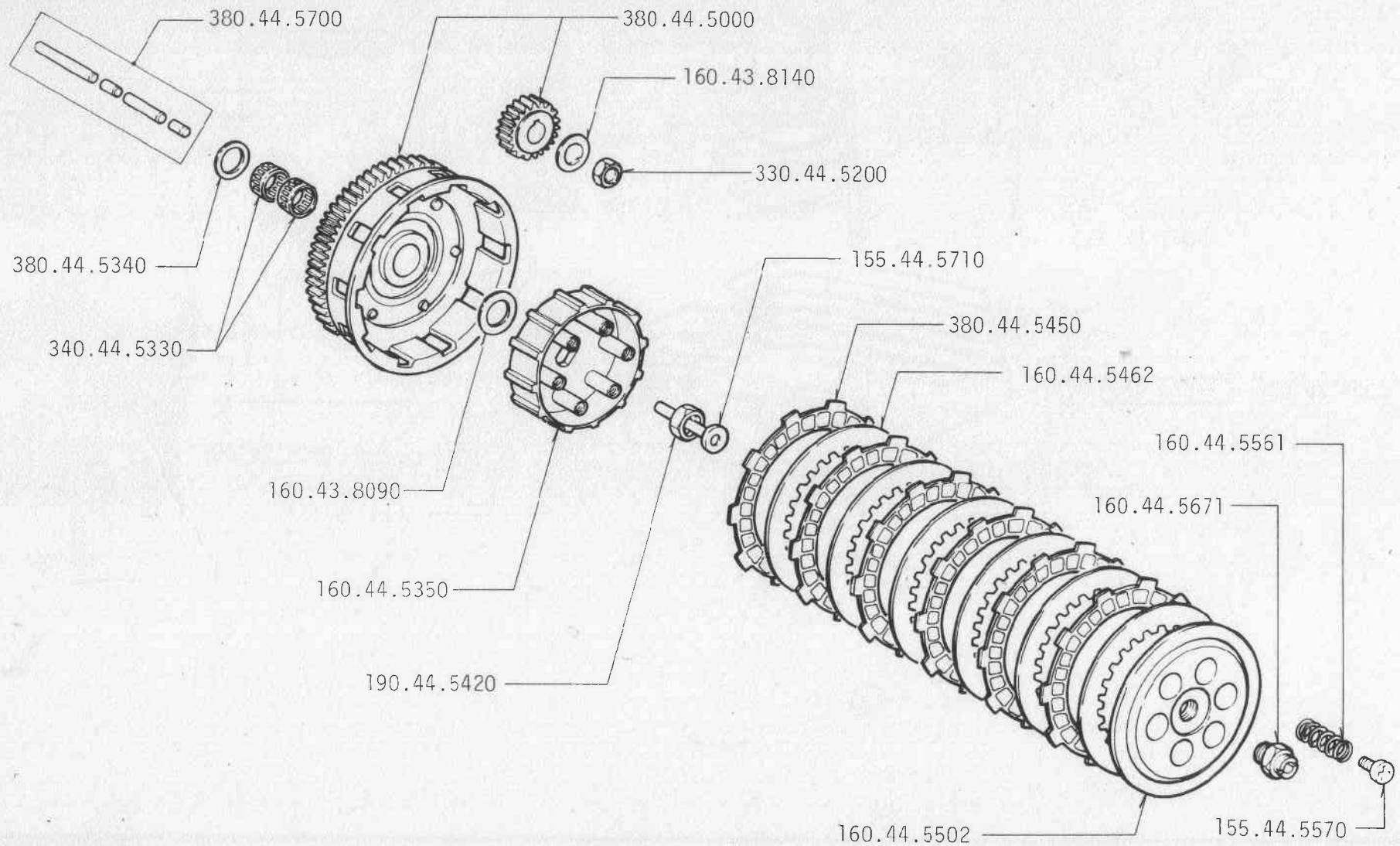

N5

CABALLERO 75cc REG. COMPETIZIONE
CABALLERO 75cc REG. STANDARD
9 - 1980

N

5/1

FANTIC MOTOR

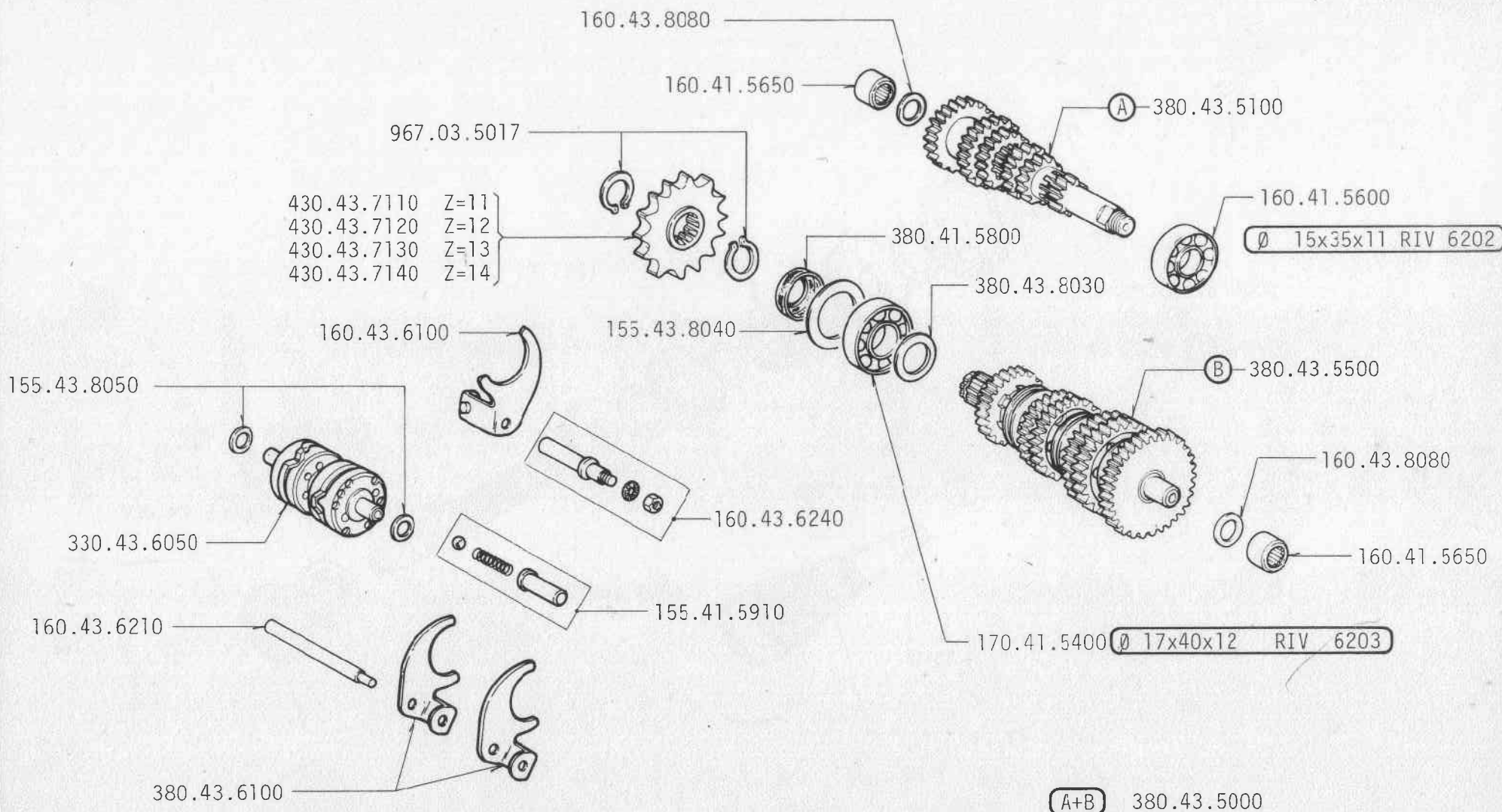

N₆

CABALLERO 75cc REG. COMPETIZIONE
CABALLERO 75cc REG. STANDARD
9 - 1980

N

6/1

FANTIC MOTOR

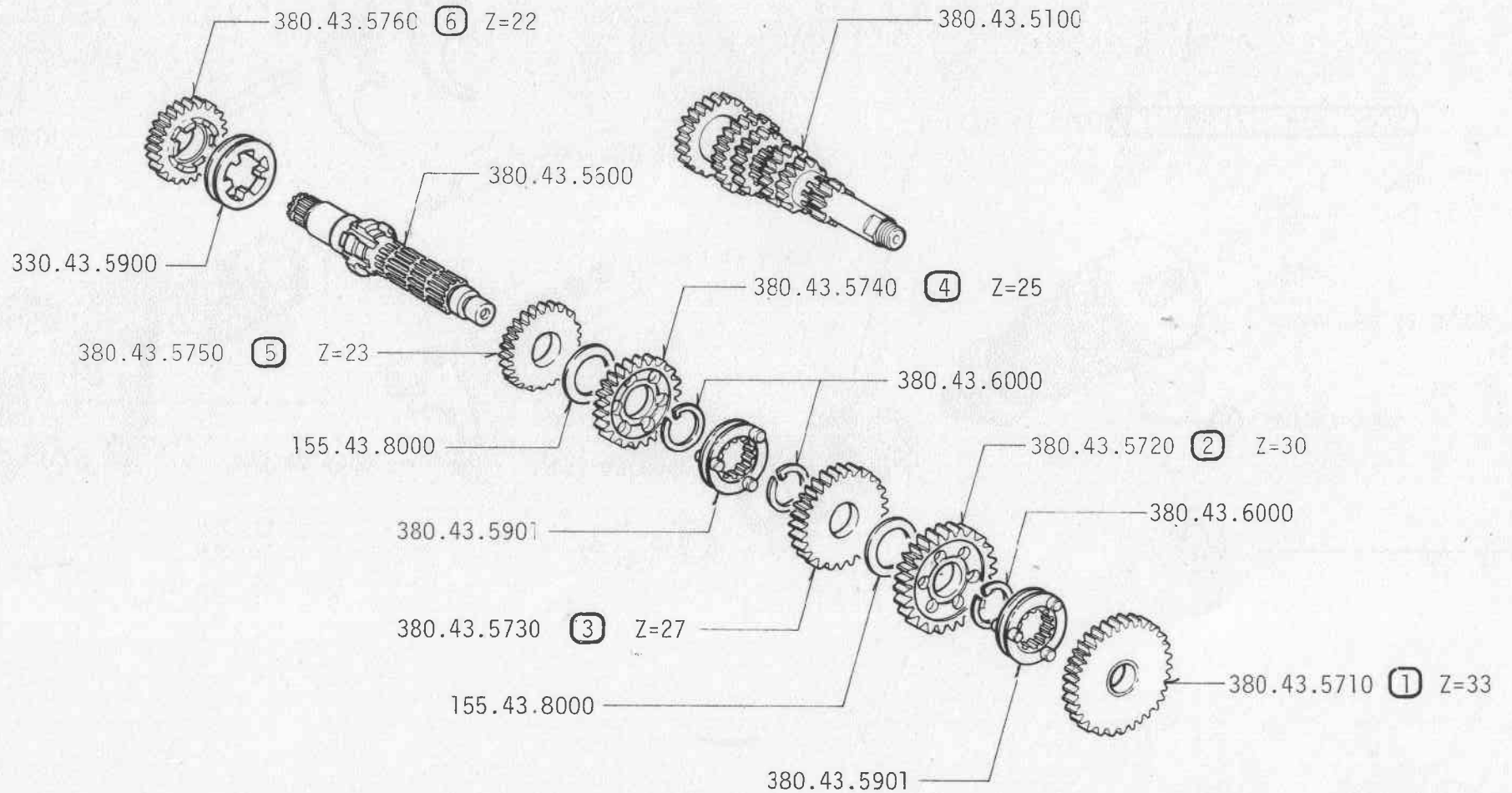

N8

CABALLERO 75cc REG. COMPETIZIONE
CABALLERO 75cc REG. STANDARD
9 - 1980

N

8/1

FANTIC MOTOR

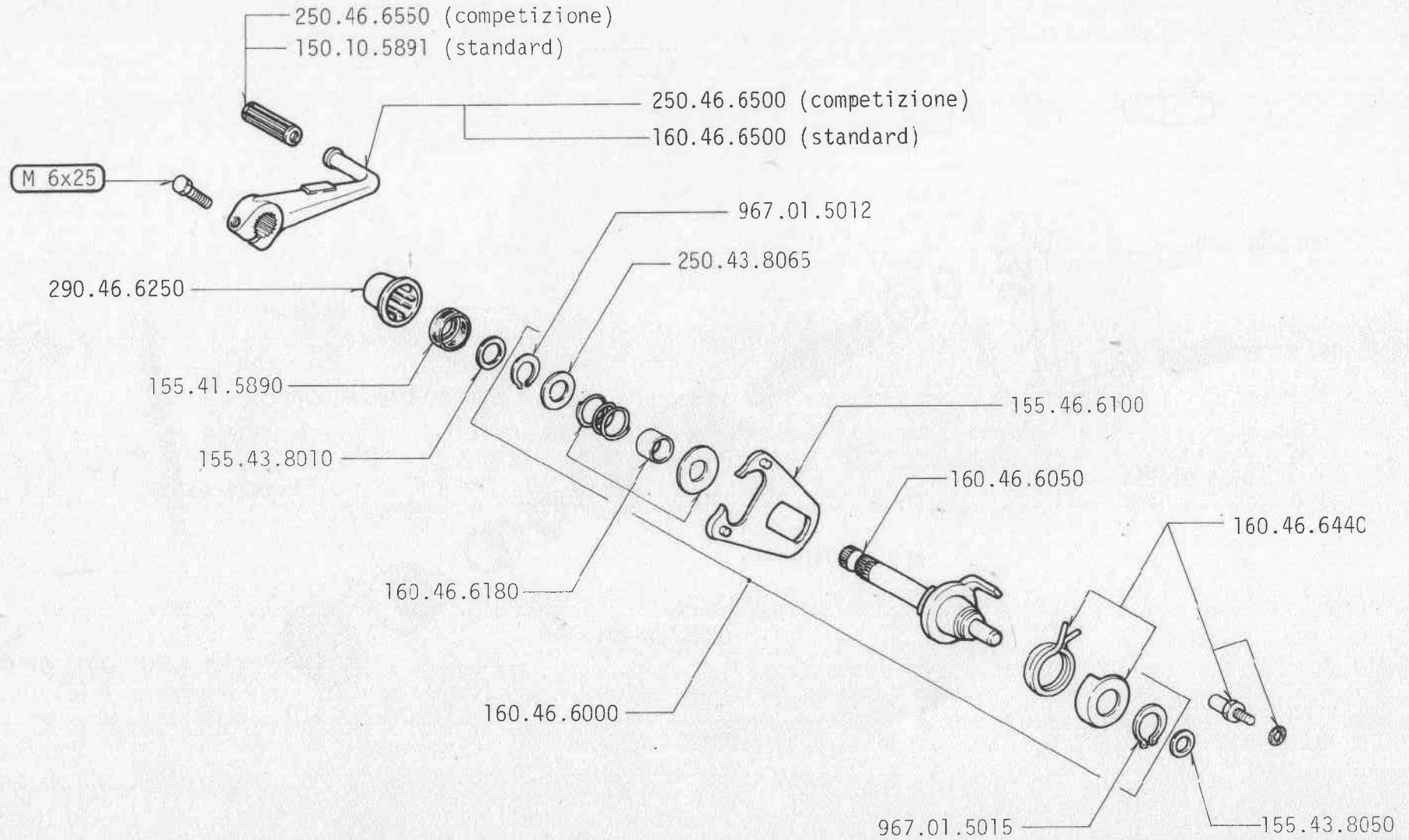

N₉

CABALLERO 75cc REG. COMPETIZIONE
CABALLERO 75cc REG. STANDARD

9 - 1980

N

9/1

FANTIC MOTOR

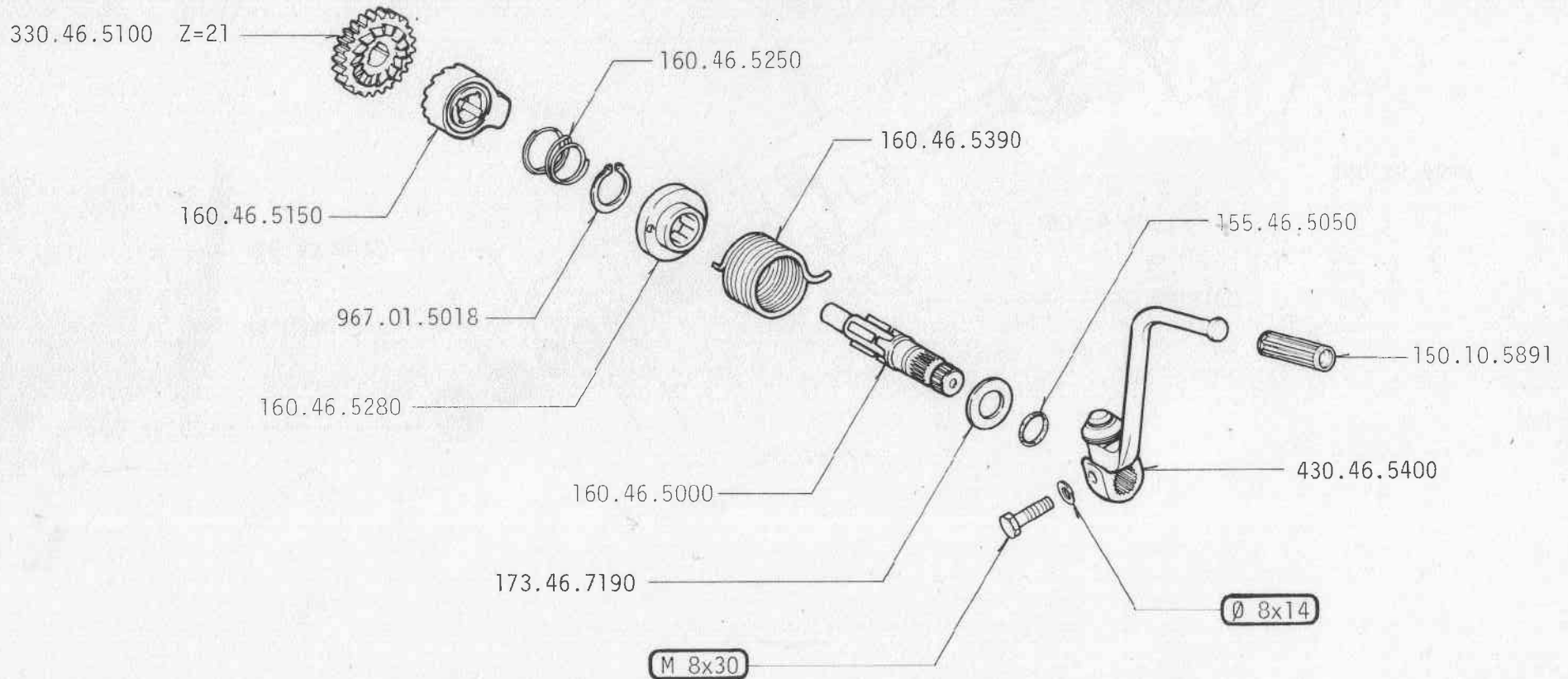

N12

CABALLERO 75cc REG. STANDARD

9 - 1980

N

12/1

FANTIC MOTOR

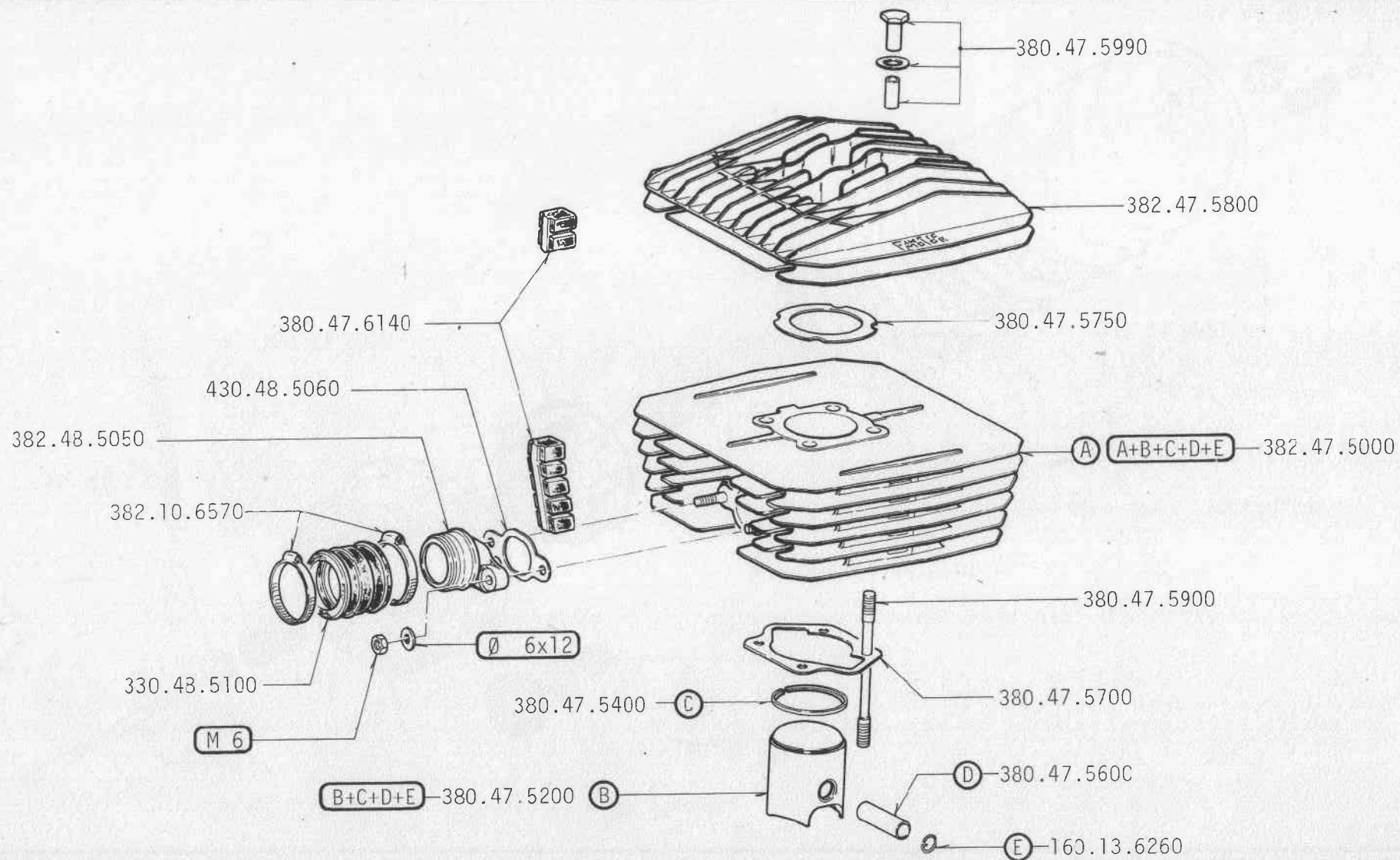

N13

CABALLERO 75cc REG. STANDARD

9 - 1980

N

13/1

FANTIC MOTOR

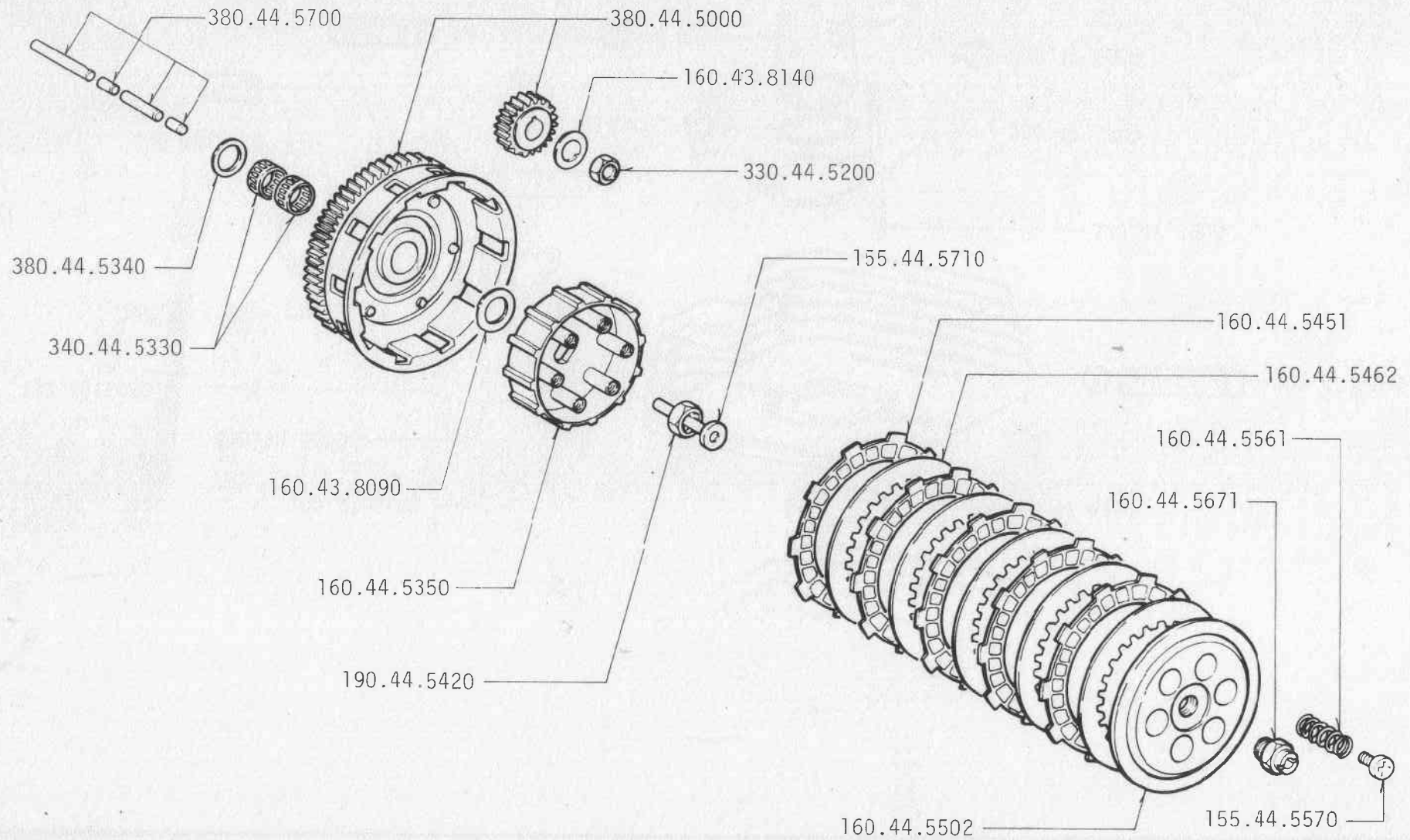



CABALLERO 75cc REG. COMPETIZIONE
CABALLERO 75cc REG. STANDARD

9 - 1980

GRUPPO ACCENSIONE
GROUPE ALLUMAGE
IGNITION GROUPE
ZÜNDANLAGE

FANTIC
MOTOR

01 CABALLERO 75cc REG. COMPETIZIONE

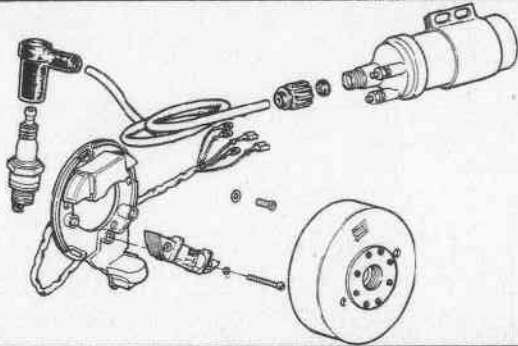

02 CABALLERO 75cc REG. STANDARD

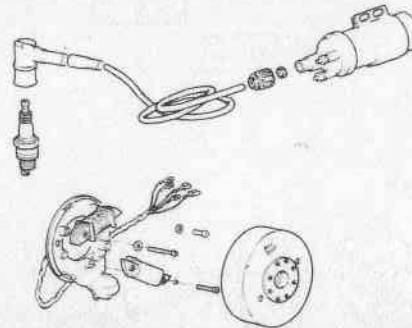

03

04

05

06

07

08

09

O1

CABALLERO 75cc REG. COMPETIZIONE

9 - 1980



1/1

FANTIC MOTOR

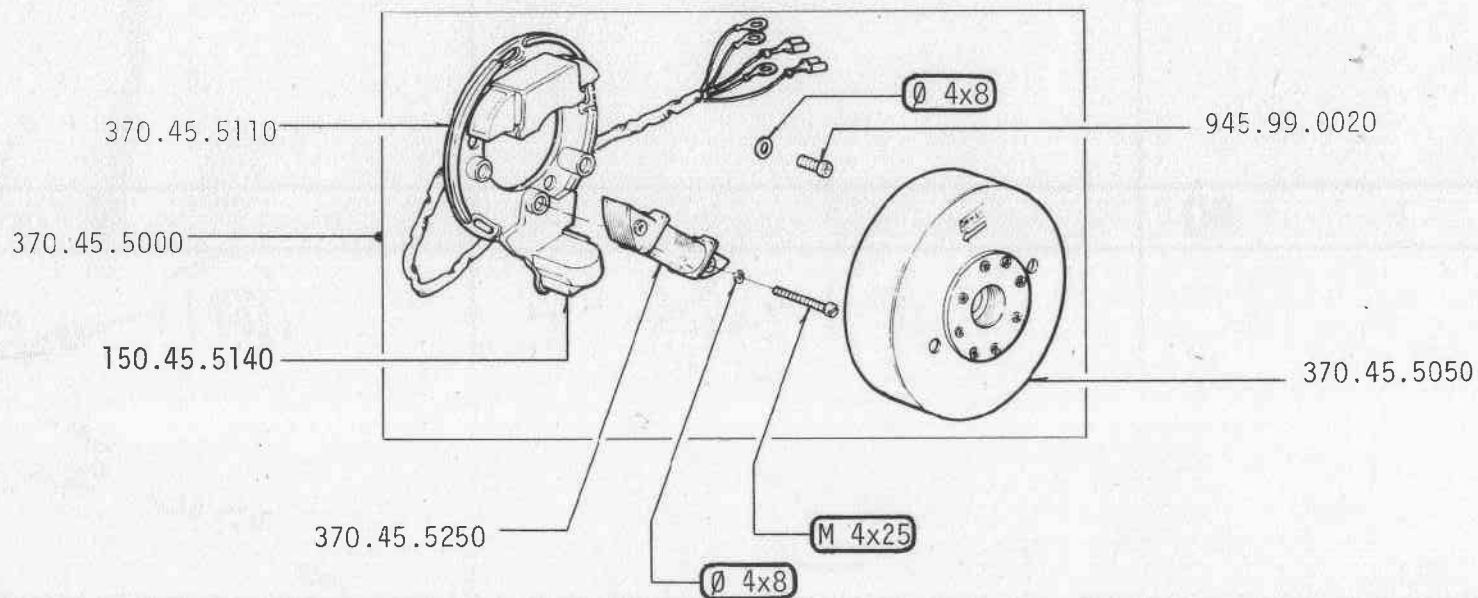
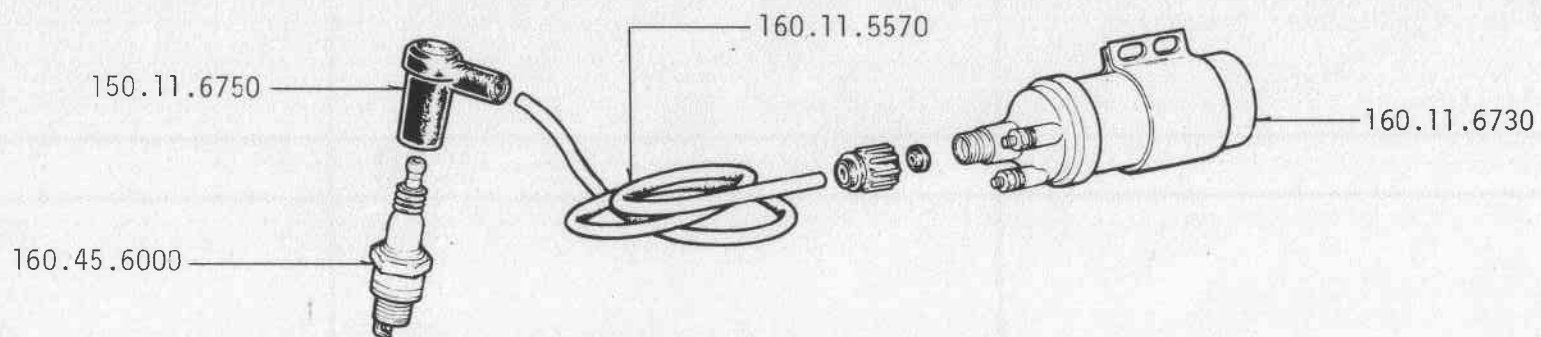

O₂

CABALLERO 75cc REG. STANDARD

9 - 1980

O

2/1

FANTIC MOTOR

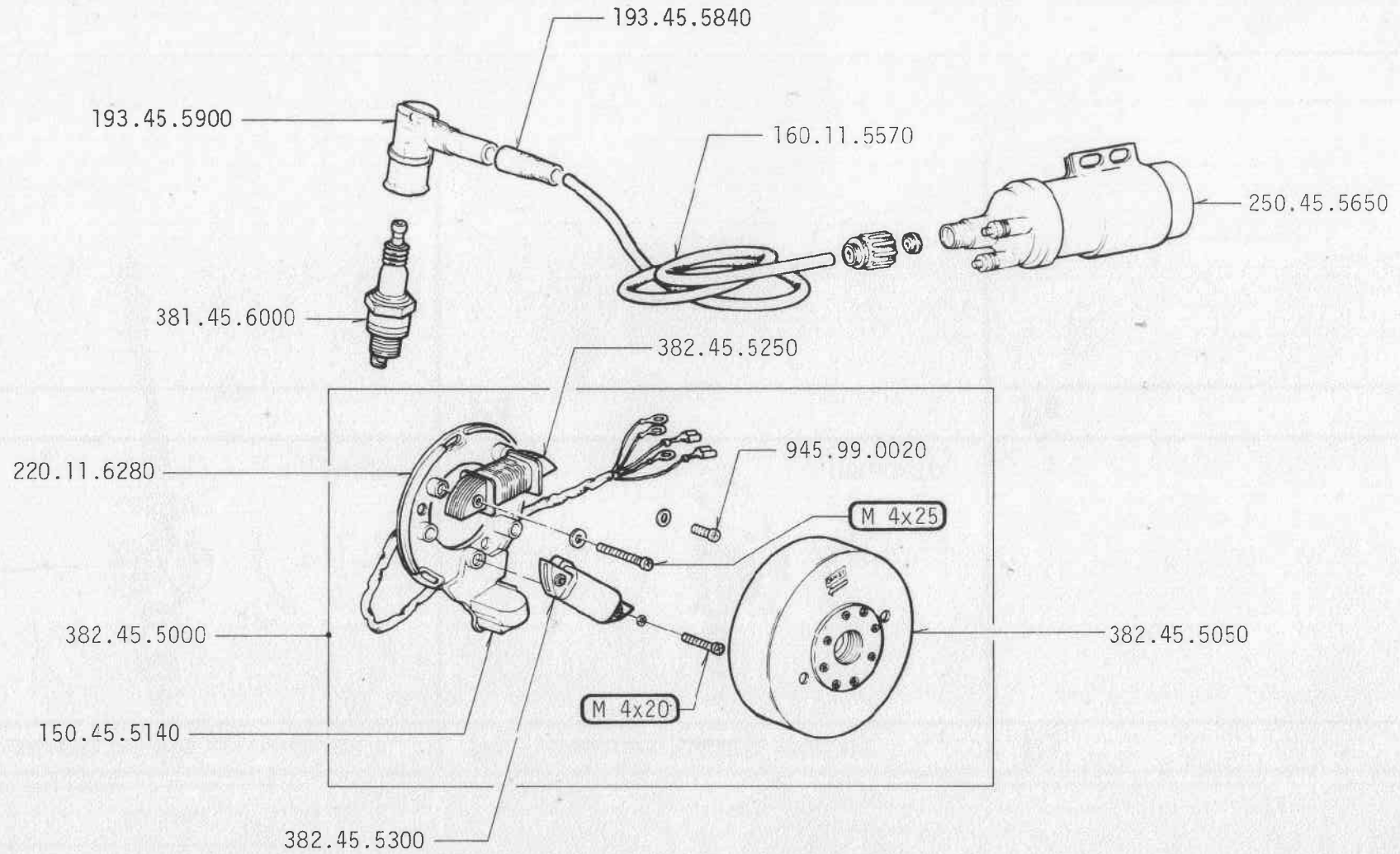

PCABALLERO 75cc REG. COMPETIZIONE
CABALLERO 75cc REG. STANDARD

9 - 1980

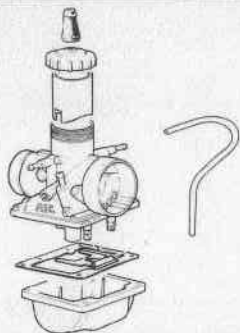
CARBURATORE
CARBURATEUR
CARBURETTOR
VERGASER**FANTIC
MOTOR****P1** CABALLERO 75cc REG. COMPETIZIONE

MIKUNI

P2 CABALLERO 75cc REG. STANDARD

DELLORTO

P3**P4****P5****P6****P7****P8****P9**

P1

CABALLERO 75cc REG. COMPETIZIONE

9 - 1980

MIKUNI VM 26-208 A

P

1/1

FANTIC MOTOR

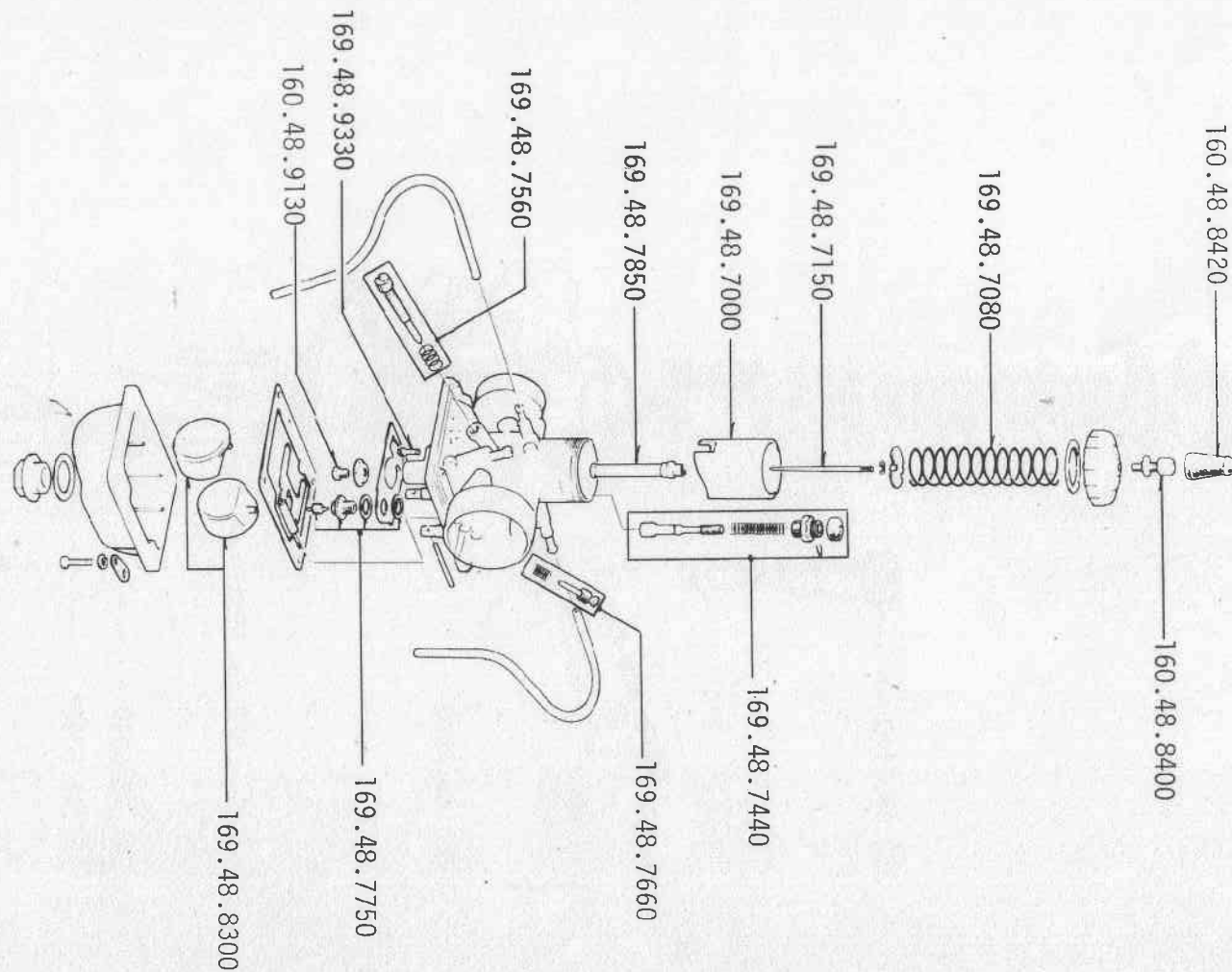

SG 169.48.5040

▲ 380.48.5000

▲ Carburatore completo

▲ Carburateur complet

▲ Carburettor complet

▲ Vergaser Komplett

Q

CABALLERO 75cc REG. STANDARD

9 - 1980

PARTICOLARI DI TRASFORMAZIONE
PIECES POUR TRANSFORMATION
CONVERSION PIECES
UMBAUTEILE**FANTIC
MOTOR**

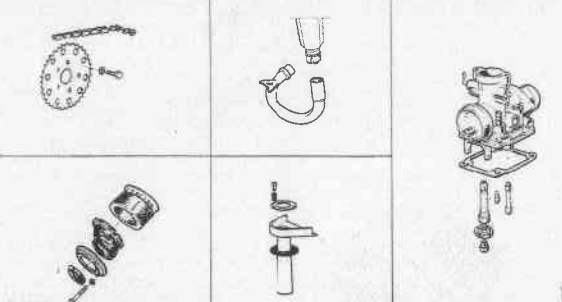
Q1 CABALLERO 75cc REG. STANDARD	Q2	Q3
		
Q4	Q5	Q6
Q7	Q8	Q9

Q1

CABALLERO 75cc REG. STANDARD

9 - 1980

Q

1/1

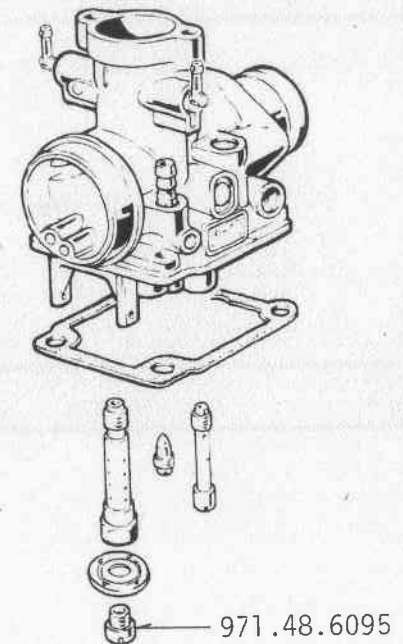
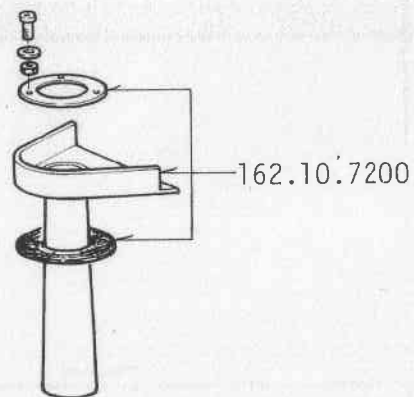
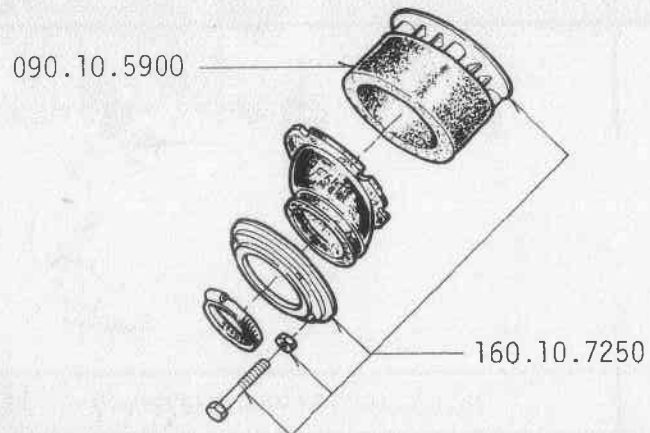
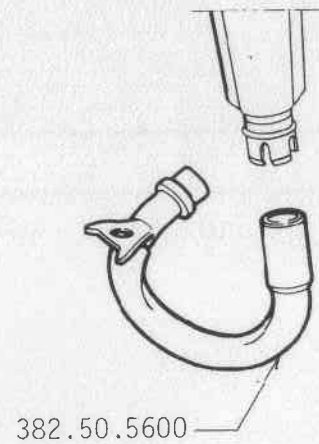
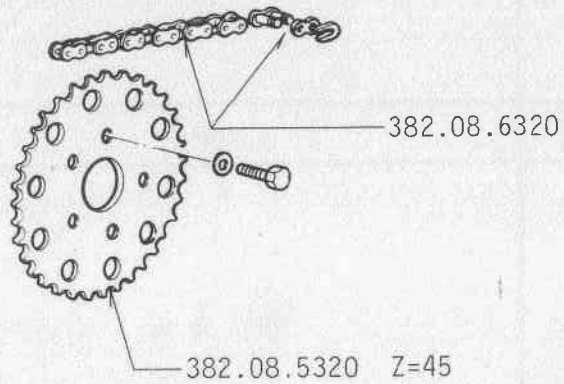
**FANTIC
MOTOR**

- Kit di trasformazione completo N. 382.50.5050
- Trousse complète pour transformation N. 382.50.5050

- Complete kit for conversion No. 382.50.5050
- Vollständiger Umwandlungskit Nr. 382.50.5050